

# ***MSC MASTER SIGNAL CONTROLLER***

By  
**The Signaling Solution**  
The Signaling Solution, Inc.  
PO Box 37  
Shelburn, IN 47879

Rev. E, June 12, 2010

Copyright 1998-2010  
The Signaling Solution, Inc.  
All Rights Reserved

# TABLE OF CONTENTS

<b>LIST OF FIGURES .....</b>	<b>4</b>
<b>1 INTRODUCTION .....</b>	<b>6</b>
<b>2 MSC OPERATIONAL FEATURES.....</b>	<b>6</b>
<b>3 GENERAL INFORMATION .....</b>	<b>7</b>
3.1 Automatic Block Signaling .....	7
3.2 Absolute Permissive Block Signaling.....	8
3.3 Centralized Traffic Control Signaling.....	9
3.4 CTC at Interlocking Plants.....	10
<b>4 PLANNING YOUR SIGNALING SYSTEM .....</b>	<b>11</b>
4.1 Standard Nomenclature .....	12
4.2 Block Signaling .....	12
4.2.1 One Direction Traffic .....	12
4.2.2 Two Direction Traffic.....	20
4.3 Passing Track Signaling.....	24
4.3.1 One Direction Traffic .....	24
4.3.2 Two Direction Traffic.....	26
4.3.3 Shared Passing Track.....	33
4.4 Crossing Signaling.....	36
4.4.1 APB Crossing .....	36
4.4.2 CTC Crossing .....	37
4.5 Detection Routing by Turnouts .....	39
<b>5 INSTALLING YOUR MSC .....</b>	<b>40</b>
5.1 Physical Installation of the MSC Board .....	41
5.2 Connecting to the Block Detectors .....	43
5.3 Getting Turnout Position .....	44
5.4 Connecting to the Signals.....	45
5.4.1 Color Light Signals.....	45
5.4.2 Position Light Signals.....	48
5.4.3 Color Position Light Signals.....	50

5.4.4	Searchlight Signals .....	50
5.4.5	Semaphore Signals .....	52
<b>5.5</b>	<b>Connecting to a CTC Panel .....</b>	<b>53</b>
<b>6</b>	<b>CUSTOMER SUPPORT .....</b>	<b>53</b>
<b>6.1</b>	<b>Technical Support .....</b>	<b>53</b>
<b>6.2</b>	<b>Limited Warranty .....</b>	<b>53</b>

## LIST OF FIGURES

Figure 3-1 Automatic Block Signaling.....	8
Figure 3-2 Absolute Permissive Block Signaling.....	9
Figure 3-3 Centralized Traffic Control.....	10
Figure 4-1 Four Sequential Blocks.....	13
Figure 4-2 Mode 0 Jumper Configuration.....	14
Figure 4-3 Three Sequential Blocks + 1.....	14
Figure 4-4 Mode 1 Jumper Configuration.....	15
Figure 4-5 Pair of Two Sequential Blocks.....	16
Figure 4-6 Mode 2 Jumper Configuration.....	17
Figure 4-7 Two Sequential Blocks + 1 + 1.....	17
Figure 4-8 Mode 3 Jumper Configuration.....	18
Figure 4-9 Four Separate Blocks.....	19
Figure 4-10 Mode 4 Jumper Configuration.....	20
Figure 4-11 Tumbledown and SIGCOM Connections.....	21
Figure 4-12 Two Sequential APB Blocks.....	21
Figure 4-13 Mode 5 Jumper Configuration.....	22
Figure 4-14 Two Individual APB Blocks.....	23
Figure 4-15 Mode 6 Jumper Configuration.....	24
Figure 4-16 ABS/CTC Passing Track.....	25
Figure 4-17 Mode 9 Jumper Configuration.....	25
Figure 4-18 APB Approach to Passing Track.....	26
Figure 4-19 Mode 7 Jumper Configuration.....	27
Figure 4-20 APB Block Between Passing Tracks.....	28
Figure 4-21 Mode 8 Jumper Configuration.....	28
Figure 4-22 ABS Passing Track Approach/Exit.....	29
Figure 4-23 Mode 10 Jumper Configuration.....	30
Figure 4-24 CTC Passing Track Approach/Exit.....	30
Figure 4-25 Mode 11 (PT) Jumper Configuration.....	31
Figure 4-26 CTC Junction Approach/Exit.....	32
Figure 4-27 Mode 11 (JCT) Jumper Configuration.....	32
Figure 4-28 ABS Shared Passing Track Type 1.....	33
Figure 4-29 Mode 12 Jumper Configuration.....	34
Figure 4-30 Shared Passing Track Type 2.....	35
Figure 4-31 Mode 13 Jumper Configuration.....	36
Figure 4-32 APB Crossing.....	36
Figure 4-33 Mode 14 (ABS) Jumper Configuration.....	37
Figure 4-34 CTC Crossing.....	38
Figure 4-35 Mode 14 (CTC) Jumper Configuration.....	38
Figure 4-36 Detection Routing by Turnouts.....	39
Figure 4-37 Mode 15 Jumper Configuration.....	40
Figure 5-1 MSC Physical Installation.....	41
Figure 5-2 Group Mounting of PC Boards.....	43
Figure 5-3 Block Detector Wiring to MSC.....	44
Figure 5-4 Isolated Block Detector Wiring to MSC.....	44
Figure 5-5 Turnout Position Contact.....	44
Figure 5-6 Turnout Position Contact on Stall Motor.....	45
Figure 5-7 Turnout Contact for High Current Stall Motor.....	45
Figure 5-8 Signal Type Jumpers for Common Anode Color Light Signals.....	46
Figure 5-9 Wiring Common Anode Color Light Signals.....	46
Figure 5-10 Signal Type Jumpers for Common Cathode Color Light Signals.....	47
Figure 5-11 Wiring Common Cathode Color Light Signals.....	47
Figure 5-12 Wiring a Color Light Signal with Bulbs.....	48

Figure 5-13 Wiring Position Light LED Signals .....	48
Figure 5-14 Wiring Position Light LED Signals for Approach Lighting .....	49
Figure 5-15 Wiring Position Light LED Signals with Common Cathodes .....	49
Figure 5-16 Searchlight Signal with 2-Pin LED.....	51
Figure 5-17 Searchlight Signal with 2-Pin Two Color LED .....	51
Figure 5-18 Wiring of a 3-Pin Common Cathode Searchlight Signal .....	51
Figure 5-19 Searchlight Signal with 3-Pin Common Cathode LED.....	52
Figure 5-20 Wiring of a 3-Pin Common Anode Searchlight Signal.....	52
Figure 5-21 Searchlight Signal with 3-Pin Common Anode LED .....	52
Figure 5-22 Dispatcher's Panel Input Connections.....	53

# 1 INTRODUCTION

Your MSC Master Signal Controller is the latest product available for helping you to implement various forms of layout signaling. It provides all of the logic needed to merge block occupancy status with turnout positions and generate prototypical signal aspects on all types of signals: color light, position light, color position light, searchlight and semaphore.

If you have ever thought seriously about installing a signaling system on your layout, you have probably already thought about the logic needed to operate your signals. We, at The Signaling Solution, certainly have. In early 1998, we developed two custom logic boards for a customer. These boards were full of digital logic chips and each only handled one very specific signaling situation.

The MSC design grew out of those developments. While the MSC has fewer parts, it will handle 18 different layout signaling situations which we all have on our layouts. It will combine block occupancy status, turnout positions and, in some cases, a dispatcher's CTC panel commands to generate three or more signal aspects on as many as four signal masts.

A "signaling situation" is a specific layout track arrangement that requires special logic. Typical signaling situations are sequential blocks signaled for Automatic Block Signaling (ABS) or Absolute Permissive Block signaling (APB), entrances to and exits from passing tracks, CTC control points, and crossings. Each such situation will normally have three or four signal masts, with 1 or more signal heads per mast. Logic within the MSC will generate the signal aspects for each such situation. In addition, the MSC has built-in logic that allows you to connect adjacent MSC boards to provide continuity from place to place around your layout.

Paragraphs in this manual will give you all the information you need. Go a step at a time, and everything will work out just fine. You'll have a signaling system that will add greatly to both your operating sessions and the appearance of your layout.

## 2 MSC OPERATIONAL FEATURES

The Master Signal Controller is used to combine turnout positions with block occupancy status and control three aspect signals. It provides the following features:

- 18 pre-programmed track configurations to providing Automatic Block, Absolute Permissive Block, and Centralized Traffic Control signaling.
- Track configurations include both one and two direction signaling of mainlines, passing tracks, junctions and crossings.
- Operates searchlight, color light, position light and semaphore signals
- Approach lighting can be turned on or off.
- Controls from four single head masts up to three two head masts, providing typical AAR aspects in each case.
- Use our line of BD boards, or equivalent devices, for train detection.
- Provided completely assembled and tested, with power supply, mounting hardware and manual.

### **3 GENERAL INFORMATION**

This section will explain the basics of the most common signaling systems used on North American prototype railroads. The information is “AAR Standard” because their standards are the starting point for prototype signaling. Naturally, the “Standard” varied over the years, based on developments in signaling and operational techniques.

Please consider these thoughts as a starting point for your signaling system. If you are building a free-lance railroad, you may be able to use these suggestions as is; if you are following a specific prototype, in a specific era, you will want to add information from other sources to keep the “rivet counters” in their place.

Over the years, the railroads have developed different systems for keeping their trains from running into each other. At first, they used manual systems, augmented by telegraph communications. In 1870, the first automatic track circuit was developed, enabling the railroads to reduce costs and improve safety. Trackside signals were installed, giving the engineer information about the condition of the track ahead. That would allow him to bring his train to a safe, controlled stop when necessary.

The foundation of train dispatching was the timetable and the rulebook, with temporary changes made by dispatcher issued train orders. The timetable was the authority for the movement of regularly scheduled trains. Also included in the timetable were the scheduled meets and passes.

Spelled out in the timetable were rules defining train superiority. When a meet was scheduled, the inferior train took the siding and cleared the switches so the superior train could pass without interference. Trains could be given ‘superiority by right’ if the dispatcher issued orders giving such superiority. Otherwise, superiority was specified in the timetable, with ‘superiority by class’ and ‘superiority by direction’.

The timetable defined the various train ‘classes’, such as first class trains are superior to second class trains, second class trains are superior to third class trains, etc. When trains of the same class meet, the timetable specified which was superior because of direction. In this way, everyone knew what needed to be done.

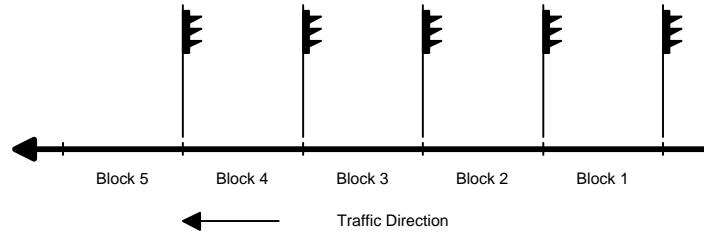
Signals were installed because things can go wrong. An air hose may break, causing a train to be late for a meet, or perhaps late in leaving a station. In either case, it would not arrive on time for a meet, or may not be as far ahead of following traffic as expected. The signals would sort this out, allowing all trains to move safely.

Two basic types of automatic signaling systems were developed: Automatic Block Signaling (ABS) and Absolute Permissive Block Signaling (APB). They are explained in detail below. In any case, with these systems, the dispatcher acted only when needed to resolve temporary problems. He issued train orders to change meeting points, to schedule extra trains, and to work around breakdowns in equipment or facilities.

Later, Centralized Traffic Control was developed. Using this system, the timetable no longer functioned as an authorizing document. Every train movement, whether regularly scheduled or extra, was handled explicitly by the dispatcher in real time. And train superiority rules were cancelled in CTC territory. More on this topic appears below.

#### **3.1 Automatic Block Signaling**

This type of signaling is used for track with train movements in only one direction. Typically, each track of a double track main line is signaled using ABS for movements in opposite directions. Should it become necessary to ‘run opposed’, the dispatcher would issue orders to the affected trains.



**Figure 3-1 Automatic Block Signaling**

In the ABS system, block lengths and signal aspects are chosen so that an engineer has adequate warning before he has to stop his train. As train speeds and sizes increased, the railroads were forced to either lengthen the blocks or add additional signal aspects. But longer blocks didn't always help because the engineer couldn't respond to a signal until he could see it. Also, since only a single train can occupy a block, longer blocks meant that trains had to run farther apart. This reduced the volume of traffic a line could handle.

As a rule, then, the railroads dealt with this by adding aspects to the signals. Instead of two aspect signaling (Red = stop, Green = proceed), they created another aspect (Yellow = approach) to tell the engineer to "proceed prepared to stop at the next signal". Additional aspects were added, which helped to engineer to bring his train to a safe stop by telling him to reduce his speed in steps. Typical values for the speed steps are:

- Normal = maximum authorized speed (timetable)
- Limited = 45 MPH for passenger trains, 40 MPH for freight trains
- Medium = 30 MPH
- Slow = 15 MPH
- Restricted = prepared to stop within one-half the range of vision, short of a train, obstruction or switch improperly aligned.

For block signaling, the MSC can provide three aspects: proceed, approach, and stop. For junctions, passing tracks and CTC control points, the MSC can provide many additional aspects.

With ABS, the stop aspect is permissive. This allows a train to stop at a red signal, and then proceed at restricted speed.

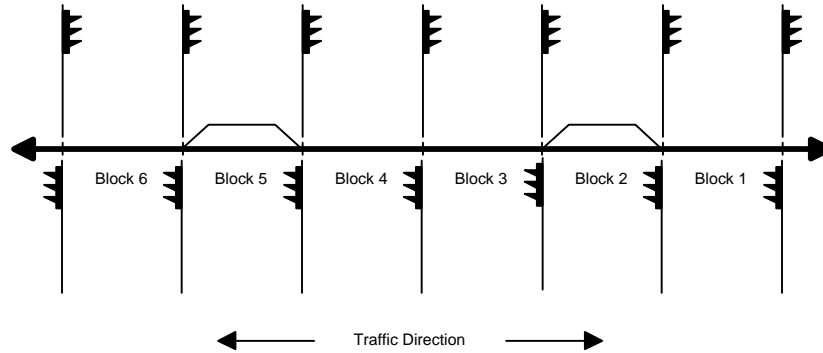
The MSC has nine operating modes that support ABS signaling.

### **3.2 Absolute Permissive Block Signaling**

APB signaling was developed to allow a single track to support train movements in both directions. This is the typical form of signaling on single-track main lines, even today.

Following movements are signaled the same as with ABS signaling. However, for opposing movements, the entire series of blocks between successive passing tracks are signaled as if they were one long block. When a train moves out of a passing track area (from either the main or the siding) and enters the single-track area, relays connected to the track circuits set the direction of the single track to be the same as the direction of the train movement. All of the opposing signals up to the next passing track 'tumble down' to display 'stop'. The opposing signal at the next passing track is an absolute signal, meaning that opposing trains are not permitted to enter the single-track section.

Other than the addition of the absolute stop aspect, the aspects and speed limits for APB are the same as for ABS.



**Figure 3-2 Absolute Permissive Block Signaling**

When you are out chasing prototype trains, you can easily recognize APB signals when you are at a passing track. There will be two single head signals, facing in opposite directions, near the points of the siding switches. Essentially, the signal facing the siding protects the entrance to the single-track territory, and is an absolute signal. Trains on either the main or the siding cannot pass an absolute stop signal.

Note also that there will probably be a phone in the immediate area. This gives an engineer a chance to call for information if he encounters an unexpected absolute stop signal. Today, with the wide use of radio communications, the line-side phone boxes are disappearing.

The MSC has five operating modes that support APB signaling.

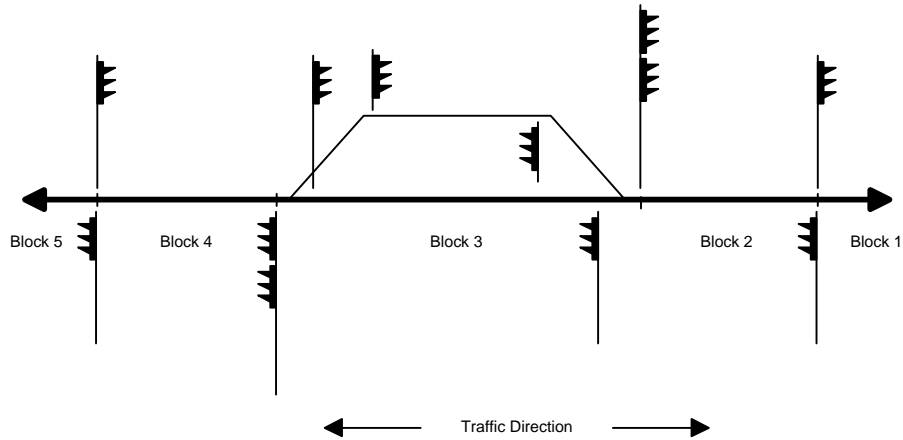
### **3.3 Centralized Traffic Control Signaling**

A later signaling development was CTC. The use of CTC will supercede the timetable as the authority for running a train. The dispatcher controls every train movement using signal aspects and remotely controlled turnouts.

But the dispatcher doesn't control all signals. He will only have control of the signals at 'control points'. These will typically be the ends of passing tracks and route entrances at interlocking plants. The dispatcher sets these signals from his panel, and the engineers are expected to respond accordingly. Between the control points, either ABS or APB circuits are used to provide absolute protection for both following and/or opposing train movements.

And, of great importance from a safety standpoint, the dispatcher can only 'request' turnouts to change position, or signals to display aspects less restrictive than stop. The track and signaling circuits in the field, called 'vital circuits', take precedence, preventing the dispatcher from throwing a switch under a train, or from giving an unsafe clear aspect.

For CTC controlled territory, you will normally see three signals at each end of a passing track. A two-head signal will control entry onto the main with the upper head, and the siding using the lower head. Separate exit signals will be provided for both main and siding near the fouling point of the turnout. These latter two signals individually control whether a train can move out onto the single-track territory.



**Figure 3-3 Centralized Traffic Control**

Depending on railroad and era, the siding departure signal may be a full mast one-head signal, a full mast two-head signal with 'stop' always displayed by the top head, or even a dwarf. The main departure signal will normally be a full mast one-head signal.

Recall that the direction of single track main lines is set by APB signaling systems when a train leaves the passing track area. With CTC, the dispatcher first sets the switch to allow departure of the desired train. Then he clears the signal for that train, setting the direction of the single-track section by signal aspect. Only then can the designated train depart.

The tumble down circuits are still in operation, preventing signals to clear opposing trains on the single-track territory.

Another feature of CTC is that the control point signals normally display the 'stop' aspect. Only when cleared by the dispatcher, and permitted to clear by the vital circuits will the signal display a less restrictive aspect. The turnout or other track at a control point has its own track circuit. As soon as a train moves past a clear signal and is detected by the track circuit, all of the signals at the control point are set to 'stop'. Thus, the dispatcher must act to clear each individual train through the control point. While this is typically true, some railroads, in very high traffic areas, allowed multiple trains to move through a cleared route, one after the other, without explicitly clearing the signal for each.

This specially detected piece of track is called an 'OS' section, meaning 'on switch', since the most common type of OS track is a switch. The OS detector also prevents the dispatcher from throwing the switch while a train is on the switch, and will set the route entrance signal to 'stop' as soon as the train enters the route.

The MSC has three operating modes that support CTC signaling.

### **3.4 CTC at Interlocking Plants**

CTC systems are also used to control interlocking plants, although a different person may actually be operating an interlocking plant. Again, the operation is similar to what was described above. In this case, interlocking signals are used to protect the entrance to routes through the interlocking plant. Beginning at any given point, several routes may be possible.

Typically, the signal, called a 'home' signal, protecting the entrance to one or more routes will have three signal heads. The top head will govern any normal speed route, the middle head will govern any medium speed route, and the lower head will govern any slow speed route. If there is no route of a particular speed, the corresponding signal head will be present and will always display 'stop'. Any exceptions to these guidelines will be described in the timetable and/or rulebook.

All signals governing the plant will normally be displaying absolute stop: red over red over red. The operator will prepare the plant for a movement by setting the various turnouts needed by the route, by locking them, and then by clearing the signal at the entrance to the route to permit a train to enter. OS circuits protect all of the switches, and a timer protects the entire route as well.

Once the signal is cleared for a route, none of the switches can be changed until the operator first sets the route signals to stop. And this doesn't unlock the turnouts. It only starts a timer holding the turnouts set for the route until any possible approaching train has had a chance to stop. If an approaching train does not have time to stop, it will run into the route while the switches are still properly aligned, and the OS circuits will prevent them from being changed until the train moves out of the route.

Route locking is also provided. With route locking, once a train has entered a route, all parts ahead of the train are locked to permit the train to proceed. As the train moves through the plant, signals are returned to the stop aspect. Track and switches no longer needed by the train, because they're behind the train, are unlocked. This allows the operator to begin setting up the next route needed.

The MSC can support many interlocking plant configurations simply by using various combinations of its other operating modes. However, because each interlocking plant is normally a unique arrangement of track and routes, expect to do special things for your interlocking plants. The Signaling Solution can provide custom designed circuit modules, based on the MSC, and programmed to handle your specific interlocking plants. Contact us to discuss how we can help you signal your special situations.

## **4 PLANNING YOUR SIGNALING SYSTEM**

While the MSC may appear to be complex, in reality, it's very simple to use. First, on a diagram of your layout, identify the locations of the signals you need. This will generally be based on the type of prototype signaling you are modeling. In Paragraph 3, we gave you some basic "AAR Standard" ideas for signal placement. Naturally, if you are following a specific prototype, you will want to gather information describing how they signaled their railroad. The AAR standards are only recommendations, and most railroads added to or modified them to suit their own situations.

Second, install three jumper plugs on the board to select the type of signal heads you are using, and another jumper plug to select approach lighting, if desired.

Third, find the MSC operational mode which handles each of your signaling situations. Install four push-on jumper plugs as shown in the mode configuration drawing. This prepares an MSC to handle each specific signaling situation.

Fourth, identify the block occupancy detectors and turnout position detectors you need to signal the situation. This information is found in each mode diagram that illustrates the signaling situations.

Finally, install, wire and test each MSC, using the connections shown in the connector diagram for the operational mode.

The following paragraphs describe each operational situation, or mode, that the MSC can support. Look through these paragraphs to find all of the information you need for each mode.

## **4.1 Standard Nomenclature**

Each of the figures shows an arrangement of blocks, block detectors, industrial spur switches and signals. The various items are labeled using the block number as a reference. For example, “BD-3” is the block occupancy detector for “Block 3”, “SW-3” is the industrial spur in “Block 3”, and “Sig-3” is the signal protecting the entrance to “Block 3”. If the block is signaled for two directions of traffic, there will be two signals labeled “Sig-3E” and “Sig-3W”, with the former protecting the eastbound entrance to “Block 3” and the latter protecting the westbound entrance.

The signals are also shown so that they indicate the direction the signal is facing. A signal above the track is facing to the right, visible to trains approaching from the right (westbound). A signal below the track is facing to the left, and is visible to trains approaching from the left (eastbound).

If an MSC input is not needed for a particular situation, don’t connect anything to the input. For example, if a block does not have an industrial spur, or you don’t want to connect it to the signaling circuit for the block, simply connect nothing to the “SW-?” input.

Your signaling system will have an electrical connection that provides a voltage reference for all of the circuits. This connection is called “SIGCOM”, or signaling common. It is thought of as having a voltage of zero volts; many people will call it “ground”, although it is not an electrical safety ground. All of the signaling circuits and the power supplies that power them must have a connection to SIGCOM. For the MSC, SIGCOM is pin V on the card edge connector.

All inputs are what are normally called “active-low inputs”, meaning that the input is active when the connected output is conducting current to SIGCOM. More information about such the actual connections will be provided in Section 5 INSTALLING YOUR MSC.

Each MSC mode diagram includes a connection table. The table shows the connections for inputs from the layout, and for outputs to the signals and other logic signals.

## **4.2 Block Signaling**

The paragraphs in this section describe the operational modes of the MSC used to operate block signals. Some of the modes handle various arrangements of blocks signaled for one direction of traffic; others handle blocks signaled for two directions of traffic.

For industrial spurs off the main line, the prototype will protect the main line by connecting both the switch and derail positions into the main line signaling circuits. In this way, if either the switch or derail are in unsafe positions, the main line signals will show a ‘stop’ aspect. Most of these MSC modes have input connections available for switches and derails. Also, the main line block signal circuit is routed through the switch so that any rolling stock that moves closer to the switch than the fouling point, or any breaks in the rails, will also activate the ‘stop’ aspect. As you can see, the prototype railroads place a maximum emphasis on safety.

### **4.2.1 One Direction Traffic**

These next five paragraphs describe the MSC modes for various arrangements of blocks signaled for one direction of traffic.

### 4.2.1.1 Four ABS Sequential Blocks

This mode of operation is used to operate three aspect signals for one direction of traffic. There are four sequential blocks to be signaled. To allow for approach lighting and three aspects, the occupancy status for six blocks is required. By grouping them this way, most of the electrical interconnections from block to block are handled internally by the MSC. You have about 1/3 as many wires to connect.

Along with the basic operation of three aspect signals, each of the blocks may have one or more industrial spurs. Whenever the spurs are not aligned for the main, the associated block signal shows 'stop', and the block signal ahead of it shows 'approach'. This exactly duplicates the operation of prototype ABS signaling.

Contacts on the switch motors for the spurs are wired into the MSC. You may also have contacts on the "derails", just as the prototype does, for a little extra interest in you operating sessions.

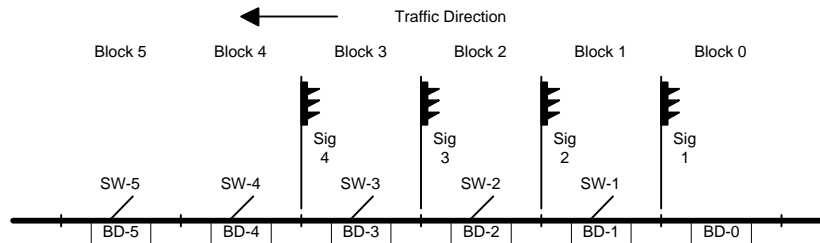
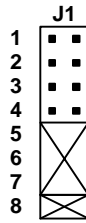


Figure 4-1 Four Sequential Blocks

MSC MODE 0			
INPUT CONNECTIONS		OUTPUT CONNECTIONS	
Pin	Function	Pin	Function
A	Block 0 occupied	1	Signal 1 RED
B	Block 1 occupied	2	Signal 1 YELLOW
C	Block 2 occupied	3	Signal 1 GREEN
D	Block 3 occupied	4	Signal 2 RED
E	Block 4 occupied	5	Signal 2 YELLOW
F	Block 5 occupied	6	Signal 2 GREEN
H	Block 1 spur and derail	7	Signal 3 RED
J	Block 2 spur and derail	8	Signal 3 YELLOW
K	Block 3 spur and derail	9	Signal 3 GREEN
L	Block 4 spur and derail	10	Signal 4 RED
M	Block 5 spur and derail	11	Signal 4 YELLOW
N		12	Signal 4 GREEN
P		13	
R		14	
S		15	
T	+ 5 Volts DC for LED's	16	
U	Vprotect (Use only with output relays)	17	
V	SIGCOM, Negative from power supply	18	Positive from power supply (+9VDC)

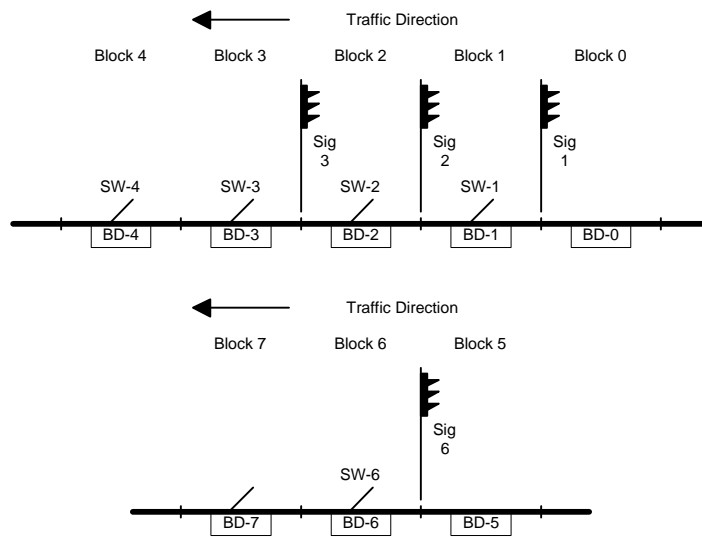
Install or remove the mode jumpers from J1 pins 1-4 as shown below.



**Figure 4-2 Mode 0 Jumper Configuration**

### 4.2.1.2 Three Sequential Blocks Plus 1

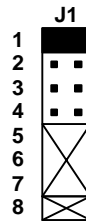
You may have an area with only three sequential blocks. By using this mode, the three blocks can be handled as a group, and the hardware resources within the MSC can still handle any one additional single block.



**Figure 4-3 Three Sequential Blocks + 1**

<b>MSC MODE 1</b>			
<b>INPUT CONNECTIONS</b>		<b>OUTPUT CONNECTIONS</b>	
Pin	Function	Pin	Function
A	Block 0 occupied	1	Signal 1 RED
B	Block 1 occupied	2	Signal 1 YELLOW
C	Block 2 occupied	3	Signal 1 GREEN
D	Block 3 occupied	4	Signal 2 RED
E	Block 4 occupied	5	Signal 2 YELLOW
F	Block 5 occupied	6	Signal 2 GREEN
H	Block 6 occupied	7	Signal 3 RED
J	Block 7 occupied	8	Signal 3 YELLOW
K	Block 1 spur and derail	9	Signal 3 GREEN
L	Block 2 spur and derail	10	Signal 4 RED
M	Block 3 spur and derail	11	Signal 4 YELLOW
N	Block 4 spur and derail	12	Signal 4 GREEN
P	Block 6 spur and derail	13	
R	Block 7 spur and derail	14	
S		15	
T	+ 5 Volts DC for LED's	16	
U	Vprotect (Use only with output relays)	17	
V	SIGCOM, Negative from power supply	18	Positive from power supply (+9VDC)

Install or remove the mode jumpers from J1 pins 1-4 as shown below.



**Figure 4-4 Mode 1 Jumper Configuration**

### 4.2.1.3 Pair of Two Sequential Blocks

More than likely, you will have a double track main line, each with two consecutive blocks to be signaled for one direction of travel. Mode 2 will handle this very nicely. While the figure shows both groups of blocks with traffic flow to the 'left', consider the traffic flow as relative to the blocks. In other words, on one main, the blocks are number 0, 1, 2 and 3 moving west; on the other, they are numbered 4, 5, 6 and 7 moving east.

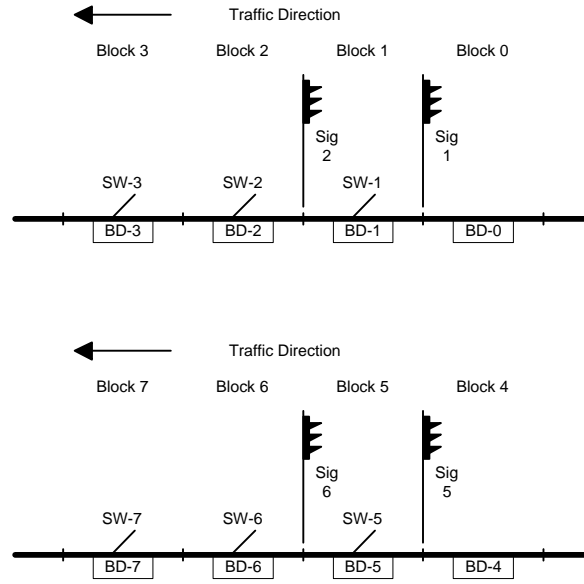
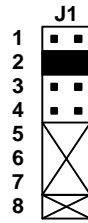


Figure 4-5 Pair of Two Sequential Blocks

<b>MSC MODE 2</b>			
<b>INPUT CONNECTIONS</b>		<b>OUTPUT CONNECTIONS</b>	
Pin	Function	Pin	Function
A	Block 0 occupied	1	Signal 1 RED
B	Block 1 occupied	2	Signal 1 YELLOW
C	Block 2 occupied	3	Signal 1 GREEN
D	Block 3 occupied	4	Signal 2 RED
E	Block 4 occupied	5	Signal 2 YELLOW
F	Block 5 occupied	6	Signal 2 GREEN
H	Block 6 occupied	7	Signal 3 RED
J	Block 7 occupied	8	Signal 3 YELLOW
K	Block 1 spur and derail	9	Signal 3 GREEN
L	Block 2 spur and derail	10	Signal 4 RED
M	Block 3 spur and derail	11	Signal 4 YELLOW
N	Block 5 spur and derail	12	Signal 4 GREEN
P	Block 6 spur and derail	13	
R	Block 7 spur and derail	14	
S		15	
T	+ 5 Volts DC for LED's	16	
U	Vprotect (Use only with output relays)	17	
V	SIGCOM, Negative from power supply	18	Positive from power supply (+9VDC)

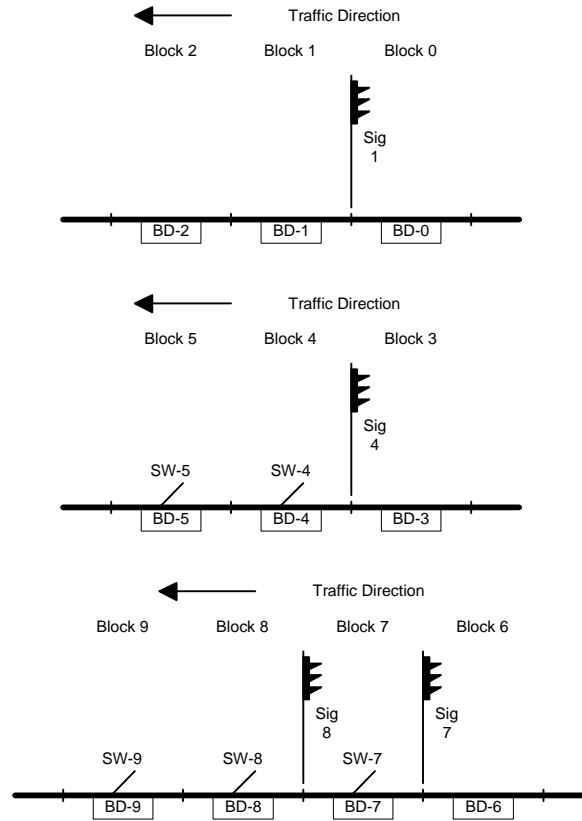
Install or remove the mode jumpers from J1 pins 1-4 as shown below.



**Figure 4-6 Mode 2 Jumper Configuration**

#### 4.2.1.4 Two Sequential Blocks Plus 1 and 1

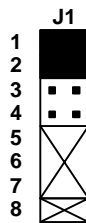
Mode 3 has one pair of consecutive blocks and two individual blocks as well.



**Figure 4-7 Two Sequential Blocks + 1 + 1**

<b>MSC MODE 3</b>			
<b>INPUT CONNECTIONS</b>		<b>OUTPUT CONNECTIONS</b>	
Pin	Function	Pin	Function
A	Block 0 occupied	1	Signal 1 RED
B	Block 1 occupied	2	Signal 1 YELLOW
C	Block 2 occupied	3	Signal 1 GREEN
D	Block 3 occupied	4	Signal 2 RED
E	Block 4 occupied	5	Signal 2 YELLOW
F	Block 5 occupied	6	Signal 2 GREEN
H	Block 6 occupied	7	Signal 3 RED
J	Block 7 occupied	8	Signal 3 YELLOW
K	Block 8 occupied	9	Signal 3 GREEN
L	Block 9 occupied	10	Signal 4 RED
M	Block 4 spur and derail	11	Signal 4 YELLOW
N	Block 5 spur and derail	12	Signal 4 GREEN
P	Block 7 spur and derail	13	
R	Block 8 spur and derail	14	
S	Block 9 spur and derail	15	
T	+ 5 Volts DC for LED's	16	
U	Vprotect (Use only with output relays)	17	
V	SIGCOM, Negative from power supply	18	Positive from power supply (+9VDC)

Install or remove the mode jumpers from J1 pins 1-4 as shown below.

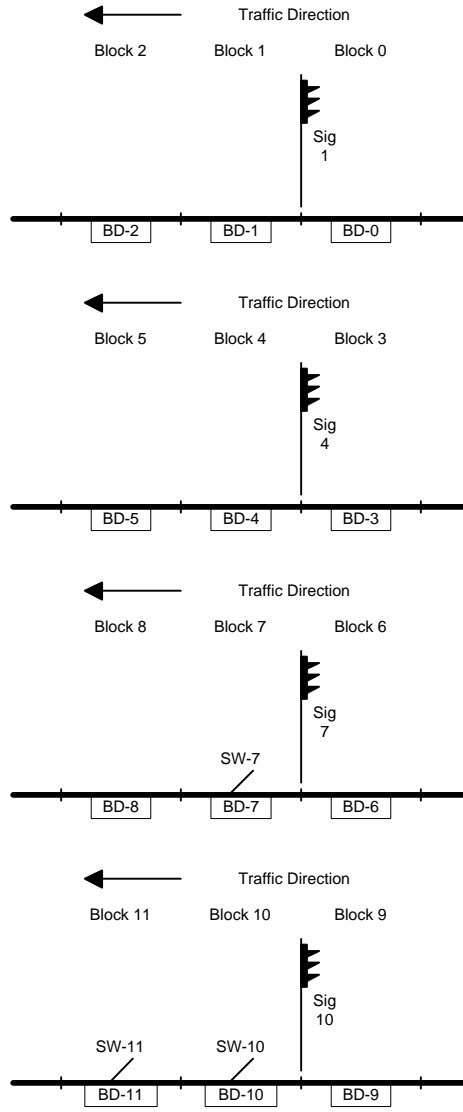


**Figure 4-8 Mode 3 Jumper Configuration**

#### 4.2.1.5 Four Separate Blocks

This mode can be used for most of your ABS situations, including all of the previous modes. In it, the approach, home and distant blocks are explicitly available for each signal.

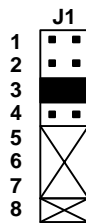
This mode does have other uses, however. Should you have a track situation with doesn't fit one of the build-in MSC modes, say a complex interlocking for example, and you can use this mode to let the MSC operate the signal heads. Use external logic as needed for the track arrangement, and pass the block occupied information in for each of the signals directly. The MSC will operate the signals properly, especially searchlight heads.



**Figure 4-9 Four Separate Blocks**

<b>MSC MODE 4</b>			
<b>INPUT CONNECTIONS</b>		<b>OUTPUT CONNECTIONS</b>	
Pin	Function	Pin	Function
A	Block 0 occupied	1	Signal 1 RED
B	Block 1 occupied	2	Signal 1 YELLOW
C	Block 2 occupied	3	Signal 1 GREEN
D	Block 3 occupied	4	Signal 2 RED
E	Block 4 occupied	5	Signal 2 YELLOW
F	Block 5 occupied	6	Signal 2 GREEN
H	Block 6 occupied	7	Signal 3 RED
J	Block 7 occupied	8	Signal 3 YELLOW
K	Block 8 occupied	9	Signal 3 GREEN
L	Block 9 occupied	10	Signal 4 RED
M	Block 10 occupied	11	Signal 4 YELLOW
N	Block 11 occupied	12	Signal 4 GREEN
P	Block 7 spur and derail	13	
R	Block 10 spur and derail	14	
S	Block 11 spur and derail	15	
T	+ 5 Volts DC for LED's	16	
U	Vprotect (Use only with output relays)	17	
V	SIGCOM, Negative from power supply	18	Positive from power supply (+9VDC)

Install or remove the mode jumpers from J1 pins 1-4 as shown below.

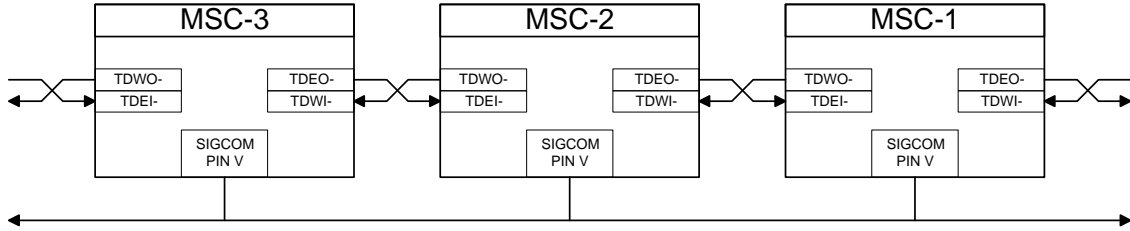


**Figure 4-10 Mode 4 Jumper Configuration**

#### 4.2.2 Two Direction Traffic

The next two paragraphs show the mode diagrams for blocks signaled for two-direction traffic flow. This type of signaling is called Absolute Permissive Block signaling. One key feature of this type of signaling is the use of tumbledown circuits to set opposing signals to the 'stop' aspect from the front of a train running in single track territory to the next passing track. These figures will show these electrical connections with the labels "TDWI" and "TDEI" for the westbound and eastbound inputs, respectively. The corresponding outputs will be labeled "TDWO" and "TDEO".

When making these connections, a tumble down west output from an MSC will be connected to the tumbledown west input of the MSC immediately to the west, and vice versa. In general, the tumbledown connections will appear as shown in Figure 4-11.



**Figure 4-11 Tumbledown and SIGCOM Connections**

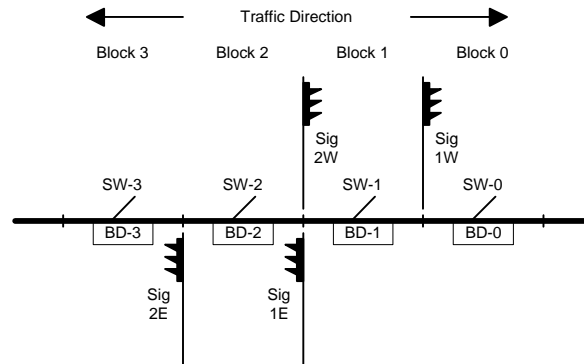
Similar tumbledown connections are used with all of the MSC modes that handle signaling for two directions of traffic flow.

### 4.2.2.1 Two Sequential Blocks

This APB mode is used if you have two sequential blocks to signal. Because of the internal routing of electrical signals, your wiring is much simpler than it otherwise would be.

There are tumbledown connections in both directions. When using this mode, expect to have a mode 7 MSC on either side to control the blocks just outside the passing tracks. For example, if you had four blocks between passing tracks, you would use 3 MSC's as follows: mode 7 – mode 5 – mode 7.

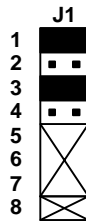
If you have only one APB block between passing tracks, use MSC mode 8 to signal that block and the entrances to the two passing tracks.



**Figure 4-12 Two Sequential APB Blocks**

<b>MSC MODE 5</b>			
<b>INPUT CONNECTIONS</b>		<b>OUTPUT CONNECTIONS</b>	
Pin	Function	Pin	Function
A	Block 0 occupied	1	Signal 1W RED
B	Block 1 occupied	2	Signal 1W YELLOW
C	Block 2 occupied	3	Signal 1W GREEN
D	Block 3 occupied	4	Signal 1E RED
E	Tumbledown West Input 1	5	Signal 1E YELLOW
F	Tumbledown East Input 2	6	Signal 1E GREEN
H	Block 0 spur and derail	7	Signal 2W RED
J	Block 1 spur and derail	8	Signal 2W YELLOW
K	Block 2 spur and derail	9	Signal 2W GREEN
L	Block 3 spur and derail	10	Signal 2E RED
M		11	Signal 2E YELLOW
N		12	Signal 2E GREEN
P		13	Tumbledown East Out Block 1
R		14	Tumbledown West Out Block 2
S		15	
T	+ 5 Volts DC for LED's	16	
U	Vprotect (Use only with output relays)	17	
V	SIGCOM, Negative from power supply	18	Positive from power supply (+9VDC)

Install or remove the mode jumpers from J1 pins 1-4 as shown below.



**Figure 4-13 Mode 5 Jumper Configuration**

#### 4.2.2.2 Two Separate Blocks

This mode handles two individual APB blocks, and has tumbledown connections in both directions to adjacent MSC's. If you have three blocks between successive passing tracks, you can use three MSC's as follows: Mode 7 – Mode 6 (1/2 of a board) – Mode 7. The mode 6 MSC board would have one APB block available for another location on your layout.

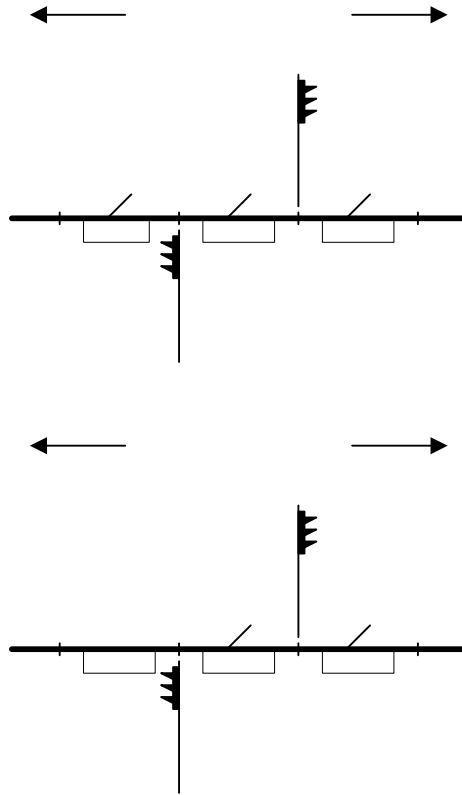
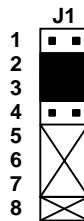


Figure 4-14 Two Individual APB Blocks

<b>MSC MODE 6</b>			
<b>INPUT CONNECTIONS</b>		<b>OUTPUT CONNECTIONS</b>	
Pin	Function	Pin	Function
A	Block 0 occupied	1	Signal 1W RED
B	Block 1 occupied	2	Signal 1W YELLOW
C	Block 2 occupied	3	Signal 1W GREEN
D	Block 3 occupied	4	Signal 1E RED
E	Block 4 occupied	5	Signal 1E YELLOW
F	Block 5 occupied	6	Signal 1E GREEN
H	Tumbledown West Input 1	7	Signal 4W RED
J	Tumbledown East Input 1	8	Signal 4W YELLOW
K	Tumbledown West Input 4	9	Signal 4W GREEN
L	Tumbledown East Input 4	10	Signal 4E RED
M	Block 0 spur and derail	11	Signal 4E YELLOW
N	Block 1 spur and derail	12	Signal 4E GREEN
P	Block 2 spur and derail	13	Tumbledown East Out Block 1
R	Block 3 spur and derail	14	Tumbledown West Out Block 1
S	Block 4 spur and derail	15	Tumbledown East Out Block 4
T	+ 5 Volts DC for LED's	16	Tumbledown West Out Block 4
U	Vprotect (Use only with output relays)	17	
V	SIGCOM, Negative from power supply	18	Positive from power supply (+9VDC)

Install or remove the mode jumpers from J1 pins 1-4 as shown below.



**Figure 4-15 Mode 6 Jumper Configuration**

### **4.3 Passing Track Signaling**

Passing tracks can be signaled in several different ways, depending on the type of signaling being used in the territory: ABS, APB or CTC. Also, passing tracks may be shared by two main lines. Typically, the railroad would locate a passing track between the two main lines. This arrangement would normally be used to permit faster traffic to overtake slower traffic.

The next several paragraphs illustrate the passing track configurations supported by the MSC.

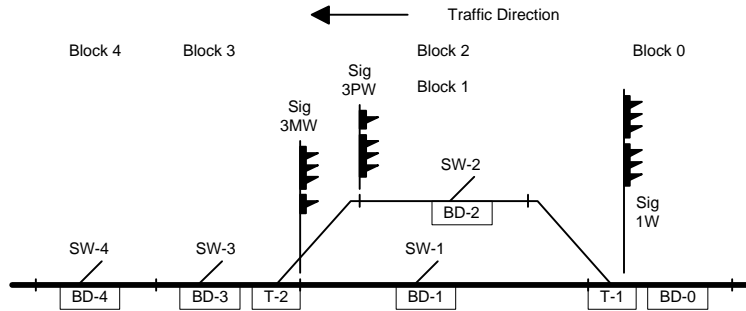
#### **4.3.1 One Direction Traffic**

Sometimes passing tracks are located on double track main lines. The primary reason is to allow faster traffic to pass slower traffic without interfering with traffic flow in the opposite direction. Naturally, these sidings are protected with signals. Quite often, the dispatcher controls the switches from his CTC panel. Since the signals only apply to one direction of traffic, the dispatcher would not have a three-position (W-S-E) direction setting switch on his panel. He would only have switches and code buttons to set turnout positions. The signals would operate automatically based on turnout positions as set by the dispatcher and block occupancy.

##### **4.3.1.1 ABS/CTC Passing Track**

An ABS/CTC passing track that is signaled for one direction of traffic flow has several possible signal configurations, depending on the specific prototype you are following. The MSC can control the signal heads shown in Figure 4-16; quite often, signals 3MW and 3PW will each have only a single three-aspect signal head. If this is your prototypes' practice, simply don't install or connect the lower head on signal 3MW and the upper head on signal 3PW.

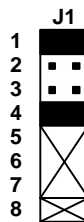
This MSC mode also has an extra output called BOCCX-0. The signal protecting the westbound entrance to block 0 needs to know the block occupancy status of the either block 1 or block 2, depending on the position of turnout 1. BOCCX-0 has this status information. Simply connect it to the MSC controlling the block 0 signal as if it were coming from a block detector on the block after block 0.



**Figure 4-16 ABS/CTC Passing Track**

<b>MSC MODE 9</b>			
<b>INPUT CONNECTIONS</b>		<b>OUTPUT CONNECTIONS</b>	
Pin	Function	Pin	Function
A	Block 0 occupied	1	Signal 1W Top RED
B	Block 1 occupied	2	Signal 1W Top YELLOW
C	Block 2 occupied	3	Signal 1W Top GREEN
D	Block 3 occupied	4	Signal 1W Bottom RED
E	Block 4 occupied	5	Signal 1W Bottom YELLOW
F	Turnout 1 Reversed	6	Signal 1W Bottom GREEN
H	Turnout 2 Reversed	7	Signal 3MW Top RED
J	Block 1 spur and derail	8	Signal 3MW Top YELLOW
K	Block 2 spur and derail	9	Signal 3MW Top GREEN
L	Block 3 spur and derail	10	Signal 3MW Bottom RED
M	Block 4 spur and derail	11	Signal 3PW Top RED
N		12	Signal 3PW Bottom RED
P		13	Signal 3PW Bottom YELLOW
R		14	Signal 3PW Bottom GREEN
S		15	BOCC Block after 0
T	+ 5 Volts DC for LED's	16	
U	Vprotect (Use only with output relays)	17	
V	SIGCOM, Negative from power supply	18	Positive from power supply (+9VDC)

Install or remove the mode jumpers from J1 pins 1-4 as shown below.



**Figure 4-17 Mode 9 Jumper Configuration**

### 4.3.2 Two Direction Traffic

There are several possible ways for passing tracks to be signaled for two directions of traffic. The first and earliest system is Absolute Permissive Block signaling. For this type of signaling, the train crew knows whether to take the siding or main based on the timetables' rules of train superiority. The dispatcher can write train orders that take precedence over the timetable when circumstances require.

The MSC has two modes available for handling APB signaled passing tracks. One mode is used if there are two or more blocks between the successive passing tracks; the other is used if there is only one block between two passing tracks.

#### 4.3.2.1 APB Approach to Passing Track

Use this mode to control APB signals if there are two or more blocks between passing tracks. If there are only two blocks, then you will use one MSC for each of the blocks, controlling a total of 6 signal heads. If there are more than two blocks, you will still have a mode 7 MSC at each passing track; signal the additional blocks using MSC boards with either mode 5 or mode 6, as appropriate.

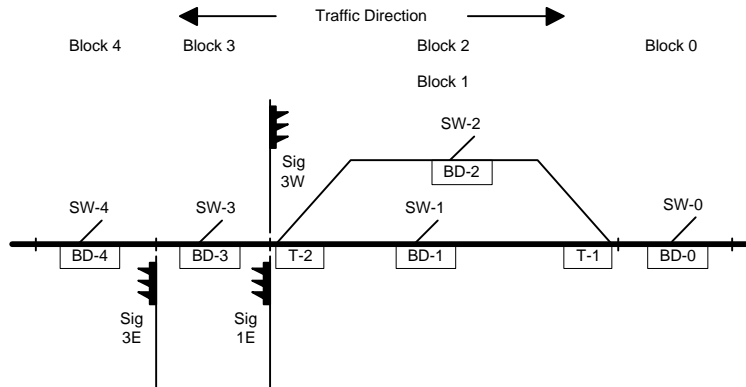
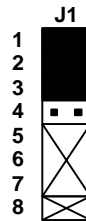


Figure 4-18 APB Approach to Passing Track

<b>MSC MODE 7</b>			
<b>INPUT CONNECTIONS</b>		<b>OUTPUT CONNECTIONS</b>	
Pin	Function	Pin	Function
A	Block 0 occupied	1	Signal 3W RED
B	Block 1 occupied	2	Signal 3W YELLOW
C	Block 2 occupied	3	Signal 3W GREEN
D	Block 3 occupied	4	Signal 1E RED
E	Block 4 occupied	5	Signal 1E YELLOW
F	Tumbledown West In Block 0	6	Signal 1E GREEN
H	Tumbledown East In Block 3	7	Signal 3E RED
J	Turnout 1 Reversed	8	Signal 3E YELLOW
K	Turnout 2 Reversed	9	Signal 3E GREEN
L	Block 0 spur and derail	10	Tumbledown East Out Block 0
M	Block 1 spur and derail	11	Tumbledown West Out Block 3
N	Block 2 spur and derail	12	
P	Block 3 spur and derail	13	
R	Block 4 spur and derail	14	
S		15	
T	+ 5 Volts DC for LED's	16	
U	Vprotect (Use only with output relays)	17	
V	SIGCOM, Negative from power supply	18	Positive from power supply (+9VDC)

Install or remove the mode jumpers from J1 pins 1-4 as shown below.



**Figure 4-19 Mode 7 Jumper Configuration**

### 4.3.2.2 APB Block Between Passing Tracks

Mode 8 is specifically designed to handle four signal heads for situations where there is only one APB block between two passing tracks.

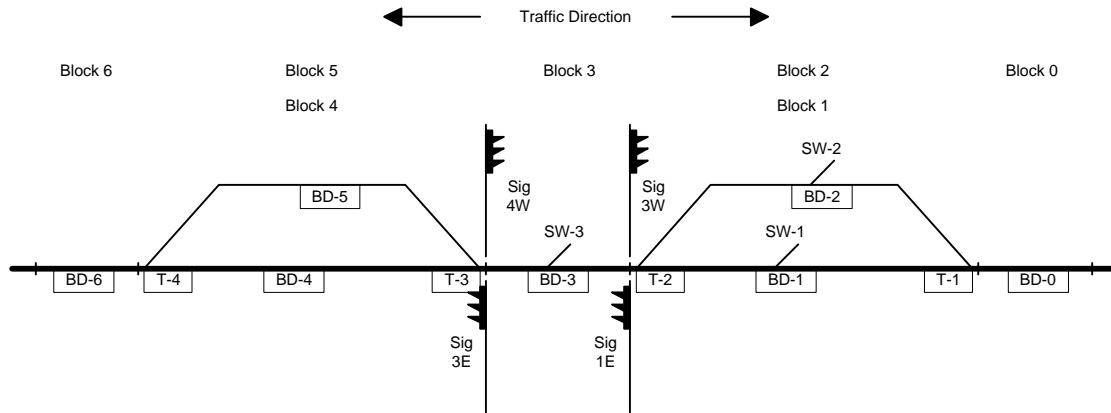


Figure 4-20 APB Block Between Passing Tracks

<b>MSC MODE 8</b>			
<b>INPUT CONNECTIONS</b>		<b>OUTPUT CONNECTIONS</b>	
Pin	Function	Pin	Function
A	Block 0 occupied	1	Signal 3W RED
B	Block 1 occupied	2	Signal 3W YELLOW
C	Block 2 occupied	3	Signal 3W GREEN
D	Block 3 occupied	4	Signal 1E RED
E	Block 4 occupied	5	Signal 1E YELLOW
F	Block 5 occupied	6	Signal 1E GREEN
H	Block 6 occupied	7	Signal 4W RED
J	Tumbledown West In Block 0	8	Signal 4W YELLOW
K	Tumbledown East In Block 6	9	Signal 4W GREEN
L	Turnout 1 Reversed	10	Signal 3E RED
M	Turnout 2 Reversed	11	Signal 3E YELLOW
N	Turnout 3 Reversed	12	Signal 3E GREEN
P	Turnout 4 Reversed	13	Tumbledown East Out Block 0
R	Block 3 spur and derail	14	Tumbledown West Out Block 6
S		15	
T	+ 5 Volts DC for LED's	16	
U	Vprotect (Use only with output relays)	17	
V	SIGCOM, Negative from power supply	18	Positive from power supply (+9VDC)

Install or remove the mode jumpers from J1 pins 1-4 as shown below.

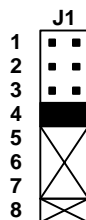


Figure 4-21 Mode 8 Jumper Configuration

### 4.3.2.3 ABS Passing Track Approach/Exit

You can use this mode to provide ABS signaling of one end of a passing track. These signals are typical of what you would use if you had a CTC installation; however, in this mode, the dispatcher clearance eastbound or westbound is 'automatic' based on turnout position. While not totally prototypical, you could have the appearance of CTC signaling without building a full CTC panel.

The single-track blocks outside the passing track area, if signaled at all, would be signaled using MSC's operating in modes 5 and 6.

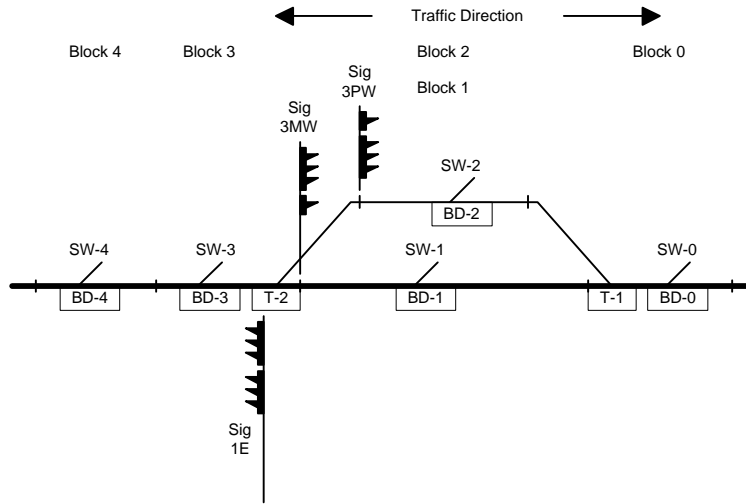
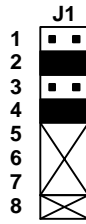


Figure 4-22 ABS Passing Track Approach/Exit

MSC MODE 10			
INPUT CONNECTIONS		OUTPUT CONNECTIONS	
Pin	Function	Pin	Function
A	Block 0 occupied	1	Signal 3PW Top RED
B	Block 1 occupied	2	Signal 3PW Bottom RED
C	Block 2 occupied	3	Signal 3PW Bottom YELLOW
D	Block 3 occupied	4	Signal 3PW Bottom GREEN
E	Block 4 occupied	5	Signal 3MW Top RED
F	Tumbledown West In Passing Track	6	Signal 3MW Top YELLOW
H	Tumbledown East In Block 3	7	Signal 3MW Top GREEN
J	Turnout 1 Reversed	8	Signal 3MW Bottom RED
K	Turnout 2 Reversed	9	Signal 1E Top RED
L	Block 0 spur and derail	10	Signal 1E Top YELLOW
M	Block 1 spur and derail	11	Signal 1E Top GREEN
N	Block 2 spur and derail	12	Signal 1E Bottom RED
P	Block 3 spur and derail	13	Signal 1E Bottom YELLOW
R	Block 4 spur and derail	14	Signal 1E Bottom GREEN
S		15	Tumbledown East Out Passing Track
T	+ 5 Volts DC for LED's	16	Tumbledown West Out Block 3
U	Vprotect (Use only with output relays)	17	BOCC Block East of Block 3
V	SIGCOM, Negative from power supply	18	Positive from power supply (+9VDC)

Install or remove the mode jumpers from J1 pins 1-4 as shown below.

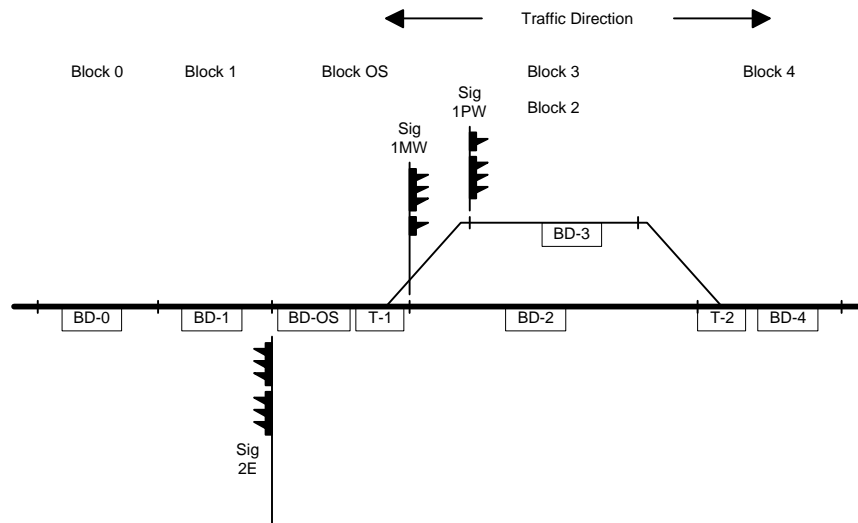


**Figure 4-23 Mode 10 Jumper Configuration**

#### 4.3.2.4 CTC Passing Track Approach/Exit

This mode gives you full CTC control over the entrance to a passing track. Your dispatcher would have a turnout and a direction switch on his panel. In normal operation, he would first select the turnout position and press his code button. This would align the turnout for either the main or siding. Then he would turn the direction switch to clear either a westbound or an eastbound movement, and press the code button again.

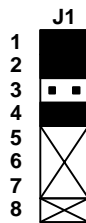
The MSC, operating in mode 11 to handle a passing track, will handle the signals accordingly. The blocks in between passing tracks would be signaled using other MSC's in modes 5 and 6. The tumbledown connections will make sure that opposing trains are not cleared into the single-track territory at the same time.



**Figure 4-24 CTC Passing Track Approach/Exit**

<b>MSC MODE 11 – CTC Passing Track</b>			
<b>INPUT CONNECTIONS</b>		<b>OUTPUT CONNECTIONS</b>	
Pin	Function	Pin	Function
A	Block OS occupied	1	Signal 2E Top RED
B	Block 0 occupied	2	Signal 2E Top YELLOW
C	Block 1 occupied	3	Signal 2E Top GREEN
D	Block 2 occupied	4	Signal 2E Bottom RED
E	Block 3 occupied	5	Signal 2E Bottom YELLOW
F	Block 4 occupied	6	Signal 2E Bottom GREEN
H	Tumbledown West In Block 1	7	Signal 1MW Top RED
J	Tumbledown East In Block 1	8	Signal 1MW Top YELLOW
K	Turnout 1 Reversed	9	Signal 1MW Top GREEN
L	Turnout 2 Reversed	10	Signal 1MW Bottom RED
M		11	Signal 1PW Top RED
N	Dispatcher Set Clear Eastbound	12	Signal 1PW Bottom RED
P	Dispatcher Set Stop	13	Signal 1PW Bottom YELLOW
R	Dispatcher Set Clear Westbound	14	Signal 1PW Bottom GREEN
S	Configuration Select (No connection)	15	Tumbledown East Out Block 1
T	+ 5 Volts DC for LED's	16	Tumbledown West Out Block 3
U	Vprotect (Use only with output relays)	17	BOCC Block East of Block 1
V	SIGCOM, Negative from power supply	18	Positive from power supply (+9VDC)

Install or remove the mode jumpers from J1 pins 1-4 as shown below.



**Figure 4-25 Mode 11 (PT) Jumper Configuration**

#### 4.3.2.5 CTC Junction Approach/Exit

Mode 11 can also be used to signal a simple CTC junction. This would normally be used where a branch line was joining a single-track main line. The other blocks on the main would be signaled using separate MSC's in modes 5 and 6, for example. The branch line may be signaled, or be 'dark territory', as you wish.

Tumbledown connections are provided so you can handle the single-track territory properly.

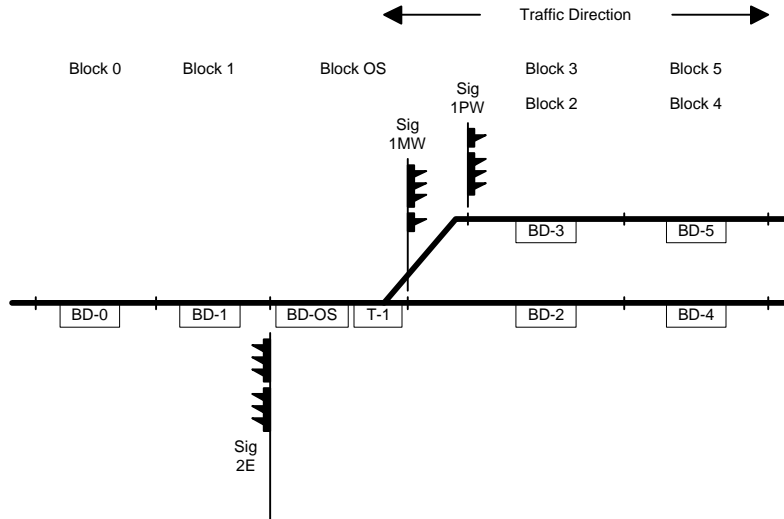


Figure 4-26 CTC Junction Approach/Exit

MSC MODE 11 – CTC Junction			
INPUT CONNECTIONS		OUTPUT CONNECTIONS	
Pin	Function	Pin	Function
A	Block OS occupied	1	Signal 2E Top RED
B	Block 0 occupied	2	Signal 2E Top YELLOW
C	Block 1 occupied	3	Signal 2E Top GREEN
D	Block 2 occupied	4	Signal 2E Bottom RED
E	Block 3 occupied	5	Signal 2E Bottom YELLOW
F	Block 4 occupied	6	Signal 2E Bottom GREEN
H	Block 5 occupied	7	Signal 1MW Top RED
J	Tumbledown East In Block 1	8	Signal 1MW Top YELLOW
K	Turnout 1 Reversed	9	Signal 1MW Top GREEN
L		10	Signal 1MW Bottom RED
M		11	Signal 1PW Top RED
N	Dispatcher Set Clear Eastbound	12	Signal 1PW Bottom RED
P	Dispatcher Set Stop	13	Signal 1PW Bottom YELLOW
R	Dispatcher Set Clear Westbound	14	Signal 1PW Bottom GREEN
S	Configuration Select to SIGCOM	15	Tumbledown East Out Block 1
T	+ 5 Volts DC for LED's	16	Tumbledown West Out Block 1
U	Vprotect (Use only with output relays)	17	BOCC Block East of Block 1
V	SIGCOM, Negative from power supply	18	Positive from power supply (+9VDC)

Install or remove the mode jumpers from J1 pins 1-4 as shown below.

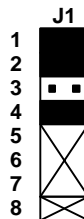


Figure 4-27 Mode 11 (JCT) Jumper Configuration

### 4.3.3 Shared Passing Track

Support for two styles of shared passing tracks is built into an MSC. A shared passing track is used by the prototype if the amount of traffic does not justify either a four-track main line, or a separate passing track for each direction. You will need an MSC to handle the signals at each end of the shared passing track.

Under normal circumstances, the dispatcher would control the turnouts and signals at each end of the siding. However, because the mains are signaled for a single direction of traffic, the MSC does not need direct connections to the dispatcher's panel. It only needs to know block status and turnout positions.

#### 4.3.3.1 ABS Without Direction Preference

Mode 12 handles the classic shared passing configuration. Either main can use the siding as needed and as controlled by the dispatcher. The signals will indicate the availability of a route through the plant, based on turnout positions and block status. You can, if you want, use the siding to cross over to the other main and run opposed to normal traffic. Be sure that train orders have been prepared and signed for!

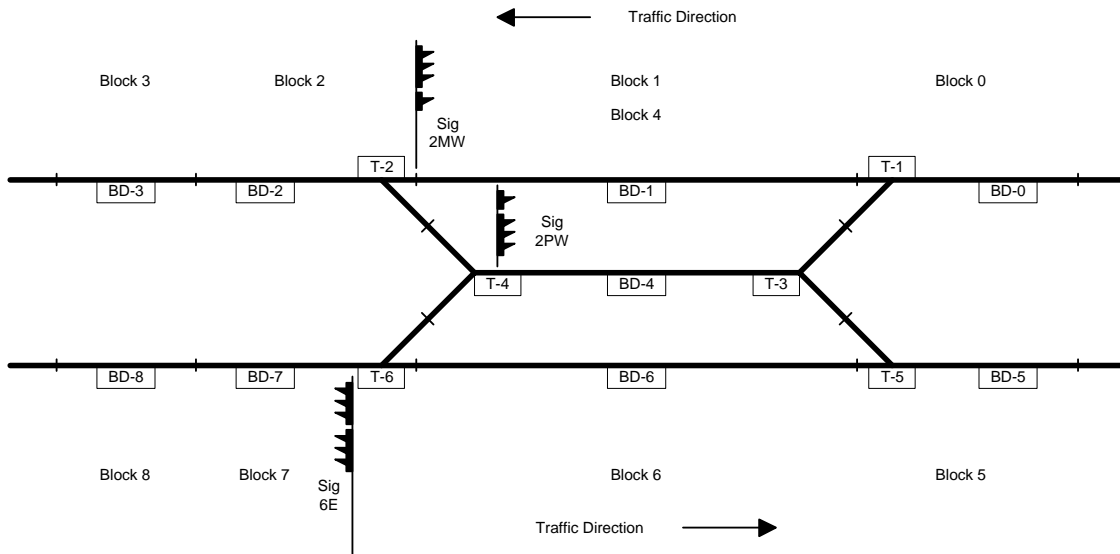


Figure 4-28 ABS Shared Passing Track Type 1

<b>MSC MODE 12</b>			
<b>INPUT CONNECTIONS</b>		<b>OUTPUT CONNECTIONS</b>	
Pin	Function	Pin	Function
A	Block 0 occupied	1	Signal 2MW Top RED
B	Block 1 occupied	2	Signal 2MW Top YELLOW
C	Block 2 occupied	3	Signal 2MW Top GREEN
D	Block 3 occupied	4	Signal 2MW Bottom RED
E	Block 4 occupied	5	Signal 2PW Top RED
F	Block 5 occupied	6	Signal 2PW Bottom RED
H	Block 6 occupied	7	Signal 2PW Bottom YELLOW
J	Block 7 occupied	8	Signal 2PW Bottom GREEN
K	Block 8 occupied	9	Signal 6E Top RED
L	Turnout 1 Reversed	10	Signal 6E Top YELLOW
M	Turnout 2 Reversed	11	Signal 6E Top GREEN
N	Turnout 3 Reversed	12	Signal 6E Bottom RED
P	Turnout 4 Reversed	13	Signal 6E Bottom YELLOW
R	Turnout 5 Reversed	14	Signal 6E Bottom GREEN
S	Turnout 6 Reversed	15	BOCC Block East of Block 7
T	+ 5 Volts DC for LED's	16	
U	Vprotect (Use only with output relays)	17	
V	SIGCOM, Negative from power supply	18	Positive from power supply (+9VDC)

Install or remove the mode jumpers from J1 pins 1-4 as shown below.



**Figure 4-29 Mode 12 Jumper Configuration**

### 4.3.3.2 ABS With Direction Preference

In some cases, based on the volume of traffic, a railroad will use the following arrangement to provide passing tracks for both mains. Obviously, the westbound main has more favorable access to the passing track because it can use the siding without affecting the eastbound main.

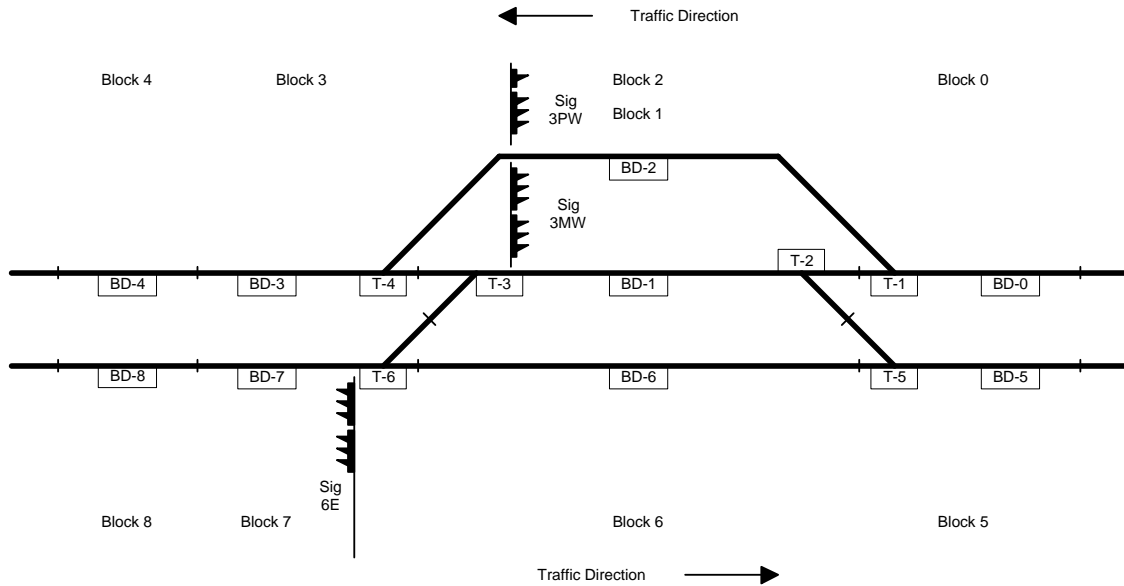
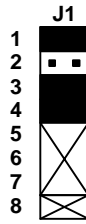


Figure 4-30 Shared Passing Track Type 2

<b>MSC MODE 13</b>			
<b>INPUT CONNECTIONS</b>		<b>OUTPUT CONNECTIONS</b>	
Pin	Function	Pin	Function
A	Block 0 occupied	1	Signal 3PW Top RED
B	Block 1 occupied	2	Signal 3PW Bottom RED
C	Block 2 occupied	3	Signal 3PW Bottom YELLOW
D	Block 3 occupied	4	Signal 3PW Bottom GREEN
E	Block 4 occupied	5	Signal 3MW Top RED
F	Block 5 occupied	6	Signal 3MW Top YELLOW
H	Block 6 occupied	7	Signal 3MW Top GREEN
J	Block 7 occupied	8	Signal 3MW Bottom RED
K	Block 8 occupied	9	Signal 3MW Bottom YELLOW
L	Turnout 1 Reversed	10	Signal 3MW Bottom GREEN
M	Turnout 2 Reversed	11	Signal 6E Top RED
N	Turnout 3 Reversed	12	Signal 6E Top YELLOW
P	Turnout 4 Reversed	13	Signal 6E Top GREEN
R	Turnout 5 Reversed	14	Signal 6E Bottom RED
S	Turnout 6 Reversed	15	Signal 6E Bottom YELLOW
T	+ 5 Volts DC for LED's	16	Signal 6E Bottom GREEN
U	Vprotect (Use only with output relays)	17	BOCC Block East of Block 7
V	SIGCOM, Negative from power supply	18	Positive from power supply (+9VDC)

Install or remove the mode jumpers from J1 pins 1-4 as shown below.



**Figure 4-31 Mode 13 Jumper Configuration**

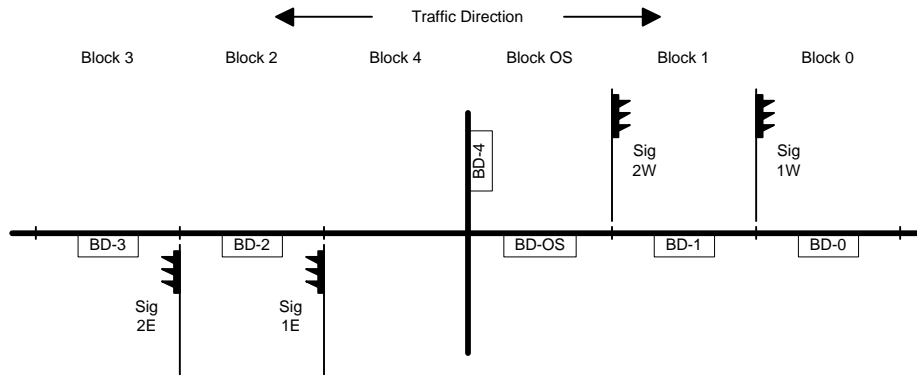
## 4.4 Crossing Signaling

Crossings are used when two tracks cross at grade. The MSC has two modes for signaling crossings. One is used for automatic operating, where the first train to arrive sets signals for the crossing route to 'stop'. The second is a CTC installation, giving the dispatcher responsibility for clearing trains through the crossing. To fully signal a crossing, you will need one MSC for each track. Each MSC controls four signals per track for two directions of traffic: the signals that protect the crossing itself, and the signals that protect the blocks approaching the crossing from either direction.

Tumbledown connections are also provided to merge these blocks into the surrounding single-track territory. Each track through the crossing has an OS section. From a signaling standpoint, the OS section is part of block 2 for westbound traffic, and part of block 1 for eastbound traffic. Block detector BD-4 detects trains in the OS section for the crossing track.

### 4.4.1 APB Crossing

Mode 14 can be used to signal a crossing automatically as shown in Figure 4-32 below. Each track operates as if it were a normal single-track main line. When a train enters its OS section, the signals for the crossing route are automatically set to 'stop'.



**Figure 4-32 APB Crossing**

<b>MSC MODE 14 - ABS</b>			
<b>INPUT CONNECTIONS</b>		<b>OUTPUT CONNECTIONS</b>	
Pin	Function	Pin	Function
A	Block OS occupied	1	Signal 1W RED
B	Block 0 occupied	2	Signal 1W YELLOW
C	Block 1 occupied	3	Signal 1W GREEN
D	Block 2 occupied	4	Signal 2W RED
E	Block 3 occupied	5	Signal 2W YELLOW
F	Block 4 occupied	6	Signal 2W GREEN
H	Tumbledown East In Block 2	7	Signal 1E RED
J	Tumbledown West In Block 1	8	Signal 1E YELLOW
K		9	Signal 1E GREEN
L		10	Signal 2E RED
M		11	Signal 2E YELLOW
N		12	Signal 2E GREEN
P		13	Tumbledown East Out Block 1
R		14	Tumbledown West Out Block 2
S	Configuration Select (No connection)	15	
T	+ 5 Volts DC for LED's	16	
U	Vprotect (Use only with output relays)	17	
V	SIGCOM, Negative from power supply	18	Positive from power supply (+9VDC)

Install or remove the mode jumpers from J1 pins 1-4 as shown below.



**Figure 4-33 Mode 14 (ABS) Jumper Configuration**

#### 4.4.2 CTC Crossing

Mode 14 also has a CTC option available. Use this if you want the dispatcher to clear traffic through the crossing manually. As with the automatic operation above, as soon as a train enters its OS section, the signals for the crossing route are set to display 'stop'. But, at the same time, the signal cleared by the dispatcher is returned to 'stop' as well. This requires the dispatcher to clear following movements one at a time.

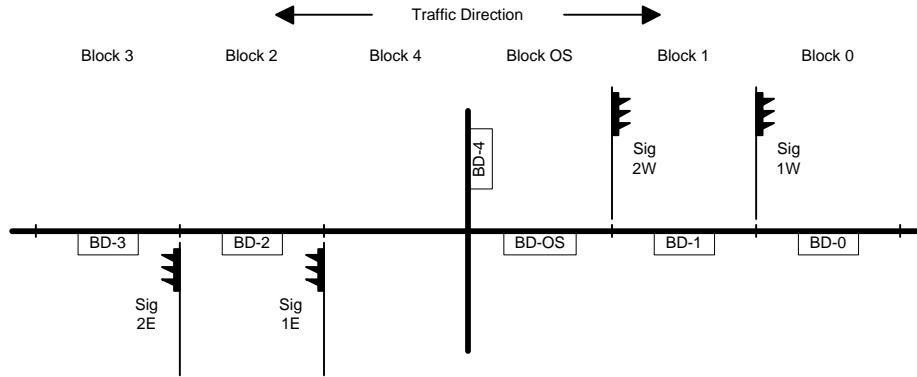


Figure 4-34 CTC Crossing

INPUT CONNECTIONS		OUTPUT CONNECTIONS	
Pin	Function	Pin	Function
A	Block OS occupied	1	Signal 1W RED
B	Block 0 occupied	2	Signal 1W YELLOW
C	Block 1 occupied	3	Signal 1W GREEN
D	Block 2 occupied	4	Signal 2W RED
E	Block 3 occupied	5	Signal 2W YELLOW
F	Block 4 occupied	6	Signal 2W GREEN
H	Tumbledown East In Block 2	7	Signal 1E RED
J	Tumbledown West In Block 1	8	Signal 1E YELLOW
K		9	Signal 1E GREEN
L		10	Signal 2E RED
M		11	Signal 2E YELLOW
N	Dispatcher Set Clear Eastbound	12	Signal 2E GREEN
P	Dispatcher Set Stop	13	Dispatcher Panel Clear East Bound
R	Dispatcher Set Clear Westbound	14	Dispatcher Panel Stop
S	Configuration Select to SIGCOM	15	Dispatcher Panel Clear West Bound
T	+ 5 Volts DC for LED's	16	Tumbledown East Out Block 1
U	Vprotect (Use only with output relays)	17	Tumbledown West Out Block 2
V	SIGCOM, Negative from power supply	18	Positive from power supply (+9VDC)

Install or remove the mode jumpers from J1 pins 1-4 as shown below.



Figure 4-35 Mode 14 (CTC) Jumper Configuration

## 4.5 Detection Routing by Turnouts

In its most basic form, a signal displays an aspect based on the condition of the blocks ahead. When a turnout provides route selection, the next block changes based on the position of the turnout. From the point side of a switch, the next block will be either along the normal or the reversed route.

From the frog side of a switch, the next block will be the point side block, if the switch is aligned for the frog track. If not aligned for the track, the 'next' block is conceptually not present, since a route to it does not exist. In other words, it's as if the next block were occupied.

This last MSC mode is used to perform this block status routing for three separate turnouts. You can use any combination of these three turnout switches to create block status routing for any junction or yard throat. In each case, the route will see the status of the next block along the route, or a forced occupied state. When presented to a signal head, using mode 4 for example, the signal will display 'stop' if the route is not available for any reason.

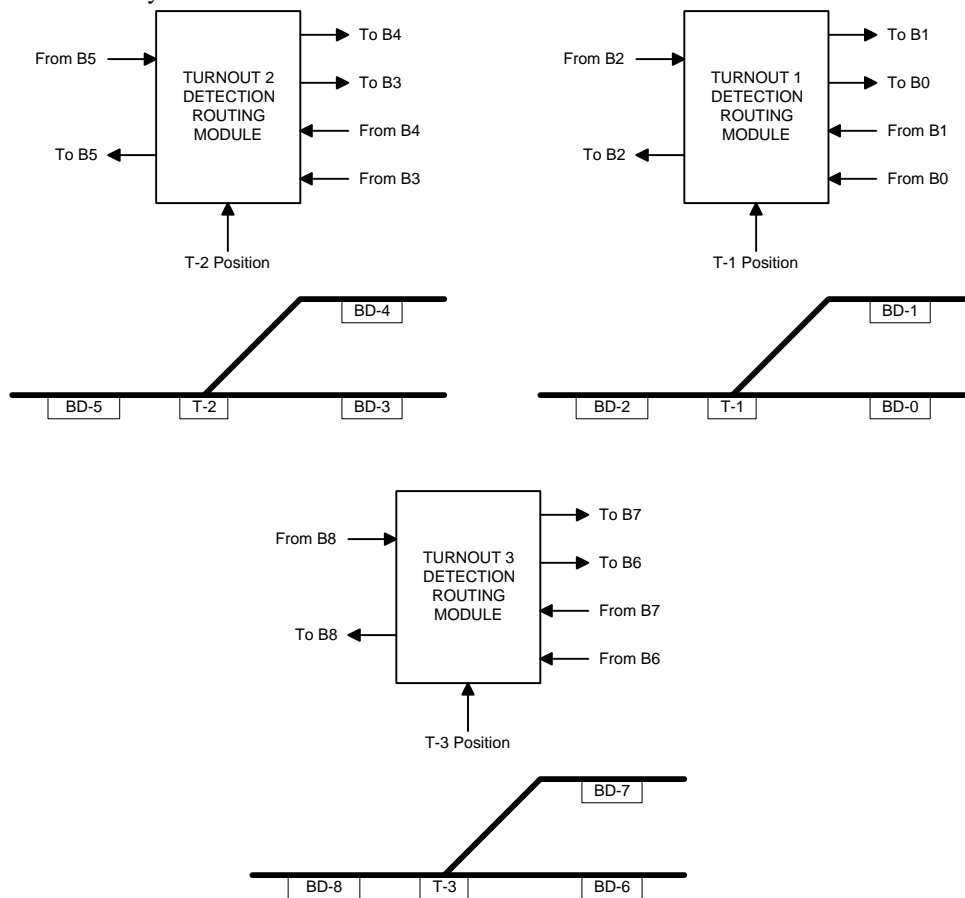


Figure 4-36 Detection Routing by Turnouts

<b>MSC MODE 15</b>			
<b>INPUT CONNECTIONS</b>		<b>OUTPUT CONNECTIONS</b>	
Pin	Function	Pin	Function
A	Block 0 occupied	1	Block Occupied West of Block 0
B	Block 1 occupied	2	Block Occupied West of Block 1
C	Block 2 occupied	3	Block Occupied East of Block 2
D	Block 3 occupied	4	Block Occupied West of Block 3
E	Block 4 occupied	5	Block Occupied West of Block 4
F	Block 5 occupied	6	Block Occupied East of Block 5
H	Block 6 occupied	7	Block Occupied West of Block 6
J	Block 7 occupied	8	Block Occupied West of Block 7
K	Block 8 occupied	9	Block Occupied East of Block 8
L	Turnout 1 Reversed	10	
M	Turnout 2 Reversed	11	
N	Turnout 3 Reversed	12	
P		13	
R		14	
S		15	
T	+ 5 Volts DC for LED's	16	
U	Vprotect (Use only with output relays)	17	
V	SIGCOM, Negative from power supply	18	Positive from power supply (+9VDC)

Install or remove the mode jumpers from J1 pins 1-4 as shown below.



**Figure 4-37 Mode 15 Jumper Configuration**

## 5 INSTALLING YOUR MSC

Having completed the planning of your installation, it's now time to install your MSC. If you have a large number of boards, or you want them all installed in a central location, check Figure 5-2 for one possible approach. Otherwise, use the single board installation approach shown in Figure 5-1.

Bear in mind that the MSC will require electrical connections to the 'occupied' outputs of block detectors, and probably to contacts on turnout position switches. Wiring these will be easier if you can group related boards together. Make sure that you will have sufficient light and physical comfort when wiring the various items together. There is no sense in making the process any more difficult than it really is.

## 5.1 Physical Installation of the MSC Board

Installation of your MSC is very simple. Very little wiring is required, and the instructions below should provide everything needed to get a normal system working perfectly.

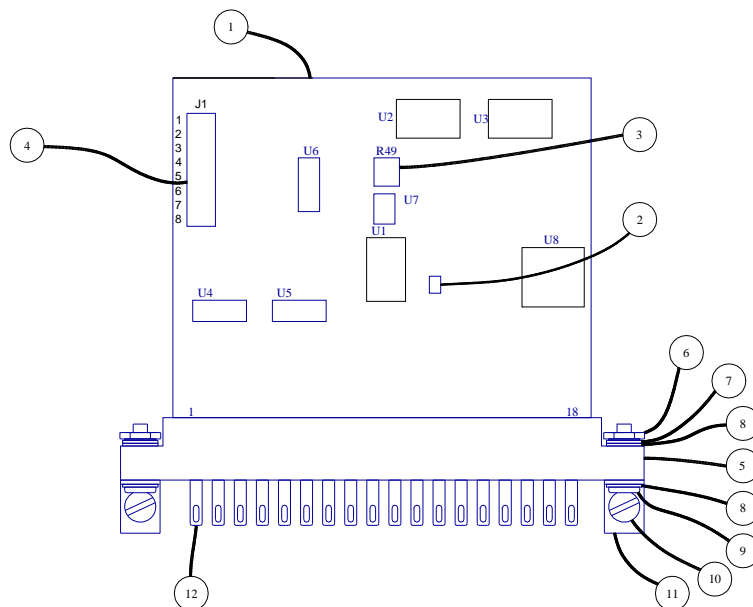
There are a few electrical connections to make. Use a small soldering iron, no more than 40 watts. A 25-watt iron would be ideal. Remember that you only have to connect one end of one wire at a time. Do that enough times, and the installation is done! Even the pros that wire the space shuttle do it that way.

Figure 5-1 MSC Physical Installation below shows how your MSC and related items will look when ready for installation. For your reference, the major items are identified individually. The mode plug and its jumpers (item 4), the board activity indicators LED (item 2), and the yellow tint control (item 3), are the only board mounted parts of interest to you. The on-board voltage regulator U8 will normally get warm during operations, especially if your signals use a lot of LED's.

Prior to installation, you will want to prepare the card edge connector (item 5) and the mounting hardware. We envision that you will mount the board to a flat surface, such as a piece of plywood or a 1x6, attached beneath your benchwork.

You will find packed in a small bag the following hardware

- Pan-head #4-40 Stainless steel machine screws (2), item 9
- Stainless steel #4 flat washer (4), item 8
- Stainless steel #4 internal tooth lock washer (2), item 7
- Stainless steel #4 hex nut (2), item 6
- Angle brackets (2), item 11.



**Figure 5-1 MSC Physical Installation**

Also identified in this figure are some of the other items of interest:

- Mode and output type selection header J1 (item 4),

- Yellow tint control for searchlight signals R49 (item 3),
- Board activity indicator LED (item 2),
- Connector pins “1” on top and “A” on bottom (item 12).

Pins 1 through 4 on J1 are used to select the operating mode; pins 4 through 7 are used to select the type of signal heads you are using. Pin 8 is used to enable or disable approach lighting. The installation of these plug-on jumpers is shown in figures that accompany each mode diagram and connection list.

The R49 Yellow tint control is provided so you can set get the best possible yellow from your red/green two color LED's. Typically, this adjustment only needs to be made once. Use a small screwdriver, and turn the control gently clockwise or counter-clockwise until you are satisfied with the yellow color. This control has no effect except when using 2-color LED's to get a yellow color.

The board activity indicator is a LED that blinks about 2 times per second whenever power is applied to the MSC. If the LED is out completely, the power supply is either not connected, or the 5-volt supply on the board is shorted to ground by a connection to pin T. If it is on, but not flashing, then the processor is not functioning. Turn off the power to the board by unplugging the AC adapter provided for about 5 seconds. Then plug it back in. If the LED still does not blink, the board may not be working. Please contact us for help in troubleshooting or to arrange for a repair.

If you have a lot of MSC's in your layout, you may find it more convenient, when installing and wiring them, to mount them in a group so that all of the connector pins are readily visible and easy to reach. One way to do this is to prepare a pair of aluminum angles, ½" x ½" by whatever length you need to mount the group of MSC's. Figure 5-2 shows one way to mount a group of our boards. Our MSC, BD8, GCC and GCX boards all use the same connector, and can be mounted as shown. The end holes in the angles are used to mount the angles to bench legs or some other type of support frame. When mounted this way, the PC boards should be in a vertical plane to allow for better cooling. Note that, because of a heat sink, a BD8 mounted in such a group needs a 1.5" spacing on the component side of the board.

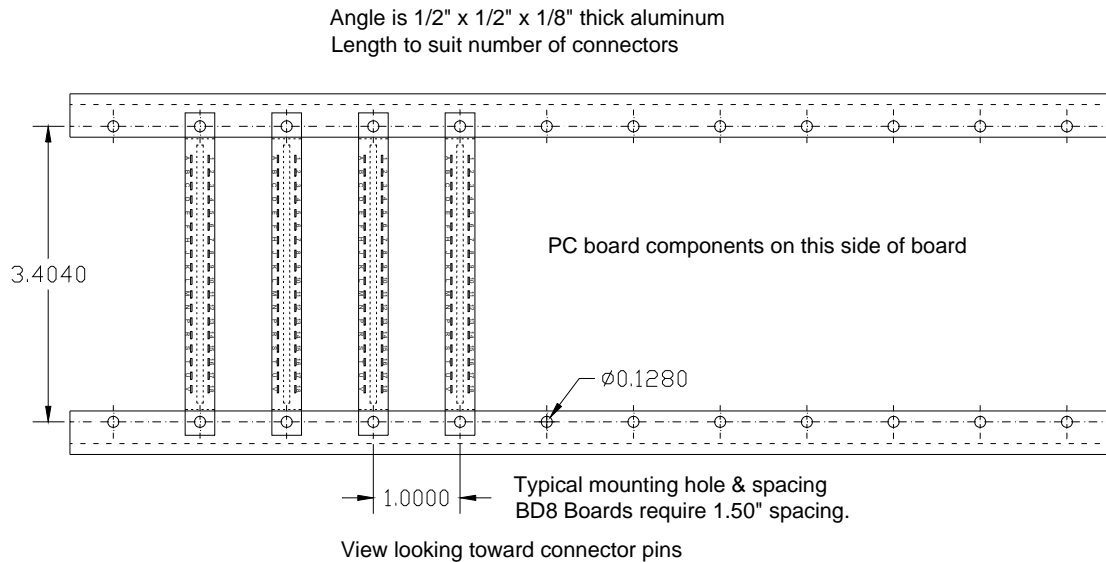
A good practice, when mounting boards in this fashion, is to use as many different colors of wire as possible, with standard colors assigned for similar purposes. For example, try using red for the red LED's, green for green LED's, yellow for yellow LED's, black for SIGCOM connections, white for +5 volts, blue for tumble down west wires, gray for tumble down east wires, tan for turnout position contacts, etc. Write down whatever colors you choose, and be sure to use the stick to your standard. It will make later troubleshooting or modifications much easier to deal with.

Also, it is much easier to work with such an assembly if you don't route the wires randomly from point to point. If this frame is mounted below your layout, route the wires to the layout up between rows of connectors and out to the layout. Route connections between connectors down below the connectors, horizontally, and then up to the proper pin. Be neat and orderly, and, except for train running circuits with a detector board such as our BD8 or BD16, use small wires. For LED's and typical incandescent bulbs, 24 to 30 gauge wire is fine for reasonable lengths, say less than 100-200 feet.

We recommend that you use stranded wire for connections out to the layout, since those wires are likely to be flexed and moved. For wires simply connecting from connector to connector, especially if you are using a group frame as shown below, solid wire is recommended. It tends to hold its shape, and can be routed neatly from point to point. When all the wiring is done, use tie wraps or cable lacing twine to bundle the wires and provide a strain relief.

Then connect the power supply provided with the MSC to the card edge connector. The power supply has a cord with a low voltage DC output. As you receive the power supply, there is a plug attached to the end of the cable. Cut off the plug as close to the end of the cable as you can. Split the two wires back from the end for about 1 ½ inches, strip about ¼ inch of insulation from each wire and attached them to the card edge connector. The wire with the white stripe gets connected to pin 18, the positive power input. Connect the other wire in the power cord to pin V.

To see if all is well, plug in the wall module. The MSC board activity LED, item 2 in Figure 5-1, should blink about 2 times per second. If it doesn't, there are a couple of possible problems. First, the socket you plugged into must be on. Second, the wires to pins 18 and V may be reversed. Finally, there may be a short circuit on one of your connections to the card edge connector. Track down the problem before continuing.



**Figure 5-2 Group Mounting of PC Boards**

## 5.2 Connecting to the Block Detectors

After you have sketched each signal situation, label the sketch with the specific block detectors and turnout position contacts to be used. Associate your names for these items with the names shown in the mode diagrams. If you carefully build and check your sketch, your names for the blocks and turnouts, and the corresponding names in the mode diagram, you will greatly reduce the chance for error.

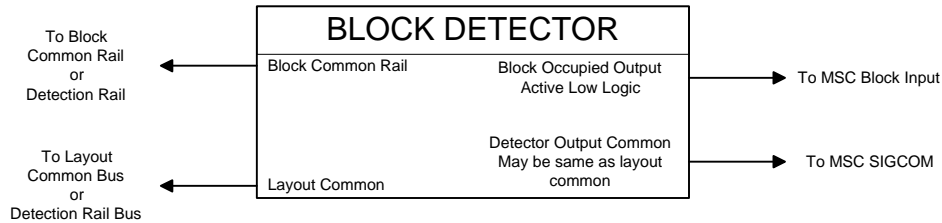
One suggestion that may help is this. Most of the figures are shown with an implied direction of traffic or arrangement of blocks and turnouts. For example, most diagrams for passing track modes are shown with the single-track territory to the left, and the main and siding to the right. To make it easier to visualize your actual track arrangement, turn the mode diagram over and trace a version from the other point of view. Naturally, the labels will all remain associated with the same switches and blocks. But it may be easier for you to visualize things more clearly.

In some cases, you may want to provide optical isolation between the block detector output and the inputs to the MSC. This is necessary if your layout is not wired with a single, layout wide common rail connection. While DC layouts frequently are wired with a single layout common, some brands of DCC, because of the booster design, prefer or require not having different booster outputs connected together.

You can certainly wire your own isolator circuits, or you can use our ISO8 Eight Channel Optical Isolator. This simple board will help you isolate your detectors. It includes 8 isolators and the necessary current limiting resistors. The output is appropriate for passing logic signals to our MSC or TC4 boards, as well as to computers or other circuitry.

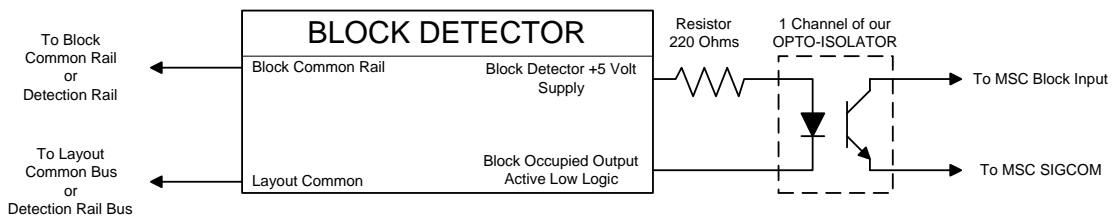
If your layout does use common rail wiring, connect 'SIGCOM' (Pin V) from each MSC to the layout common. Naturally, your block detectors will be connected in the same way. Once this is done, simply connect your block detector occupied output to the proper input pins on your MSC boards. For this, just follow your layout sketch and connect the detectors as shown in the MSC mode connection lists.

The next figure shows the typical non-isolated connections between block detectors and MSC block input pins.



**Figure 5-3 Block Detector Wiring to MSC**

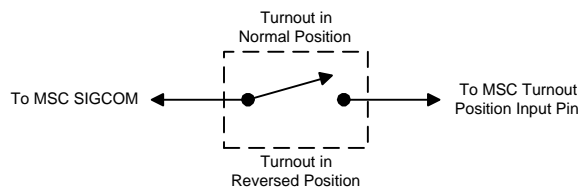
Figure 5-4 shows the use of an opto-isolator to avoid making connections between the layout running circuit common and the signaling system common.



**Figure 5-4 Isolated Block Detector Wiring to MSC**

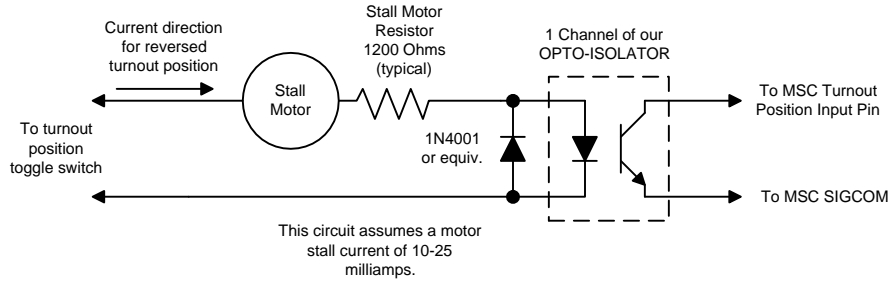
### 5.3 Getting Turnout Position

Many of the modes require turnout position inputs for proper operation. This is simply an SPST normally open contact that is closes when the turnout is in the reversed position. Such contacts are often present in twin-coil and stall motor switch machines (e.g., Tortoise). For each such turnout, connect the switch position contact as shown below.



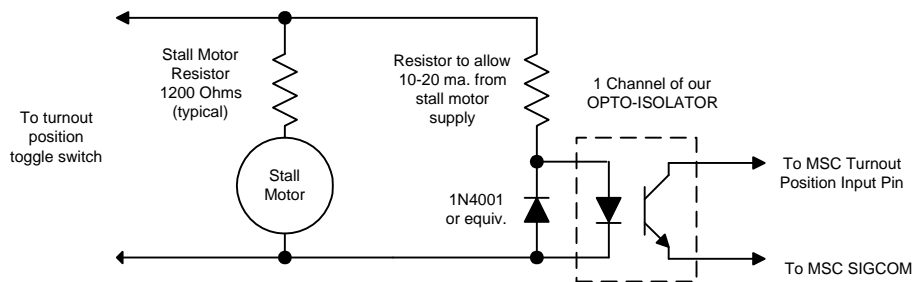
**Figure 5-5 Turnout Position Contact**

Of course, you may be using a stall motor that does not have any electrical contacts, or, perhaps, all of the contacts are already in use for frog wiring or other purposes. There is a simple, reliable way to add a "contact" to such switch machines.



**Figure 5-6 Turnout Position Contact on Stall Motor**

This circuit will work very well. If your stall motor has too high a current for this circuit, you can modify the circuit as shown in Figure 5-7



**Figure 5-7 Turnout Contact for High Current Stall Motor**

## 5.4 Connecting to the Signals

So far, we have been connecting your MSC's to the blocks and turnouts that control the aspects displayed. Now it is time to connect to the signals themselves. As you can see, the MSC can handle every type of signal in common use: color light, position light, color position light, searchlight and semaphore. The next few paragraphs will show you how to connect to the signals of your choice.

### 5.4.1 Color Light Signals

Color light signals are the one LED or bulb per aspect signal that were traditionally used by many roads, such as the D&RGW and NYC. Whether the three lens per head were stacked vertically or in a triangular shape, they are wired the same way. And the MSC will operate both LED and bulb based signals of this type.

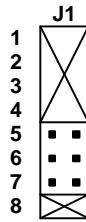
The built-in 5-volt power supply will work fine for LED's; you must use an external power supply for incandescent bulbs.

#### 5.4.1.1 LED Signal Heads

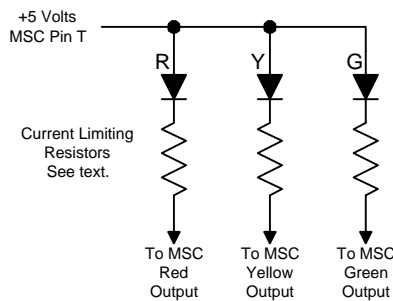
LED based signals are the easiest to use. The power supply is included with the MSC, and only a single resistor per LED is needed. Each of the three colors has a separate output that controls one of the three

LED's. However, different signal manufacturers wire their LED's differently. Some will use common anode wiring (e.g., TOMAR), while others will use common cathode (e.g., ISS). While the MSC can handle either, the most efficient for the MSC is the common anode wiring. Check with your signal manufacturer to see how he wires his signals. Some will wire the signals in whatever way you specify. In such cases, ask for common anode wiring.

If you have common anode signals, set the output programming jumpers as shown in Figure 5-8. This jumper configuration can be used for color light signals using bulbs, also. Then, wire each signal head as shown in Figure 5-9.



**Figure 5-8 Signal Type Jumpers for Common Anode Color Light Signals**



**Figure 5-9 Wiring Common Anode Color Light Signals**

As you probably know, red LED's are typically brighter than either yellow or green LED's. What many people do is to use different resistor values for the three different colors. A higher value will allow less current to flow, and the LED will not be as bright. This is a subjective process, and trial and error may be the best way to get the results you want. Once you know the values for the specific signals you use, you just use the same values everywhere.

First, pick starting values for each resistor. Your LED's will have specifications, probably included with the signals that will tell you the voltage drop across the LED when it is conducting a specific current. Use these values to calculate the resistors. The voltage drop across LED's will typically be from 1.7 to 2.6 volts, and the maximum current rating will be in the range of 10 to 30 milliamps. Using the numbers for your LED's, calculate the resistor value using:

$$R = (5 - V)/I$$

Where V is the forward voltage drop and I is the maximum LED current limit. Typically, the lowest resistor value will be 160 ohms.

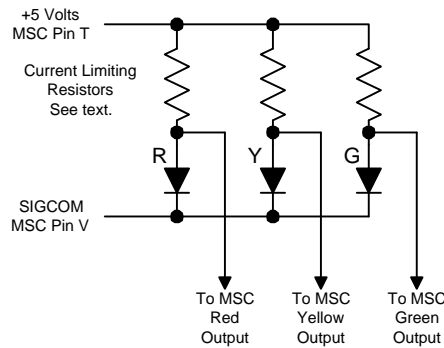
Do this calculation for each of the 3 LED's in your color light signal, and hook up the signal on your bench with all three LED's on. Compare the brightness of the three LED's, and increase the resistance of the brighter LED's until they match the brightness of the dimmest. Then, note the values and use these same

values wherever you use signals of the same type. As long as the LED voltage is greater than 1.5 volts, and the resistor value is greater than 100 ohms, a 1/8 watt rating is just fine if the supply is 5 volts.

If your signal manufacturer only provides signals wired using the common cathode method, simply change the jumpers to be as shown in Figure 5-10. You can use the same method as described above to select the resistor values. The wiring to the signal is slightly different, as shown in .



**Figure 5-10 Signal Type Jumpers for Common Cathode Color Light Signals**



**Figure 5-11 Wiring Common Cathode Color Light Signals**

### 5.4.1.2 Incandescent Bulb Heads

The MSC can operate incandescent bulbs, but two things have to be done first. As you probably know, an incandescent bulb, when first turned on, has a very low filament resistance. This causes a brief, but very high current to flow while the filament warms up. This high current surge can be as high as 10 or 20 times as much as the ‘normal’ bulb current.

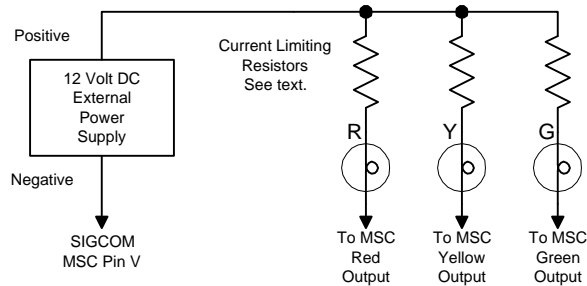
If you are using low voltage bulbs, you may be tempted to operate them from the 5-volt MSC supply. The current surge, however, can easily exceed the capacity of the MSC power supply for a fraction of a second. This would cause the MSC processor to reset, restart, activate the bulb, and reset again repeatedly. It would appear as if it’s not working, but the problem is simply the bulb turn-on current. So, if you want to use bulbs, you must use an external DC power supply of no more than 12 volts.

Second, the current surge could be enough to damage the MSC output transistors. To prevent this, install a surge-limiting resistor in series with the bulbs. If you are powering 12-volt bulbs from a 12-volt supply, use a resistor value of 47 ohms. This value will limit the surge, and reduce the voltage to the bulb about 10%, thereby significantly increasing the life of the bulb.

If you are powering low voltage bulbs from a 12-volt supply, you will need a large resistor in any case. The value of this dropping resistor will be sufficiently high to provide the necessary current limiting. For

example, if you are using a 1.5-volt, 15-milliamp bulb, you will be using a dropping resistor of about 820 ohms, and perhaps more. This, by itself, provides all the protection the MSC output transistors will need.

While using the MSC with bulbs, use the common anode jumper configuration shown in Figure 5-9. Wire the bulbs as shown in Figure 5-12.



**Figure 5-12 Wiring a Color Light Signal with Bulbs**

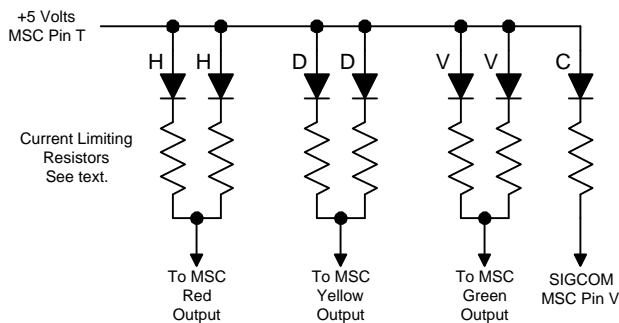
## 5.4.2 Position Light Signals

Position light signals were used by the Pennsylvania Railroad, and are still in use today. With these signals, a full signal head is a round disk with 6 or 8 fog penetrating yellow bulbs around the perimeter, and a similar bulb in the center. Naturally, model signals can be built with either yellow LED's or incandescent bulbs. The next two paragraphs show how to connect such signals to your MSC.

### 5.4.2.1 LED Signal Heads

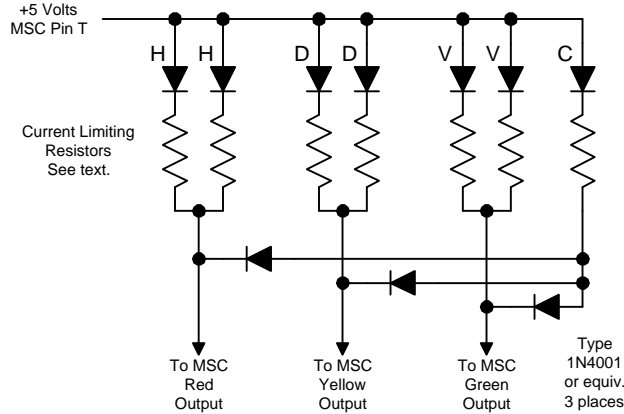
As with color light signals, position light signals can be wired with LED's in either a common anode or common cathode configuration. Figure 5-13 shows the wiring of position light signals built with LED's wired with their anodes in common. Also, this wiring will not work if you are using approach lighting, because, when wired as shown, the center light will always be lit.

In the figures below, the LED's labeled 'H' are the two horizontal LED's used to display the 'stop' aspect; the 'D' LED's are the diagonal LED's used to display the 'approach' aspect; the 'V' LED's are the two vertical LED's used to display the 'proceed' aspect.



**Figure 5-13 Wiring Position Light LED Signals**

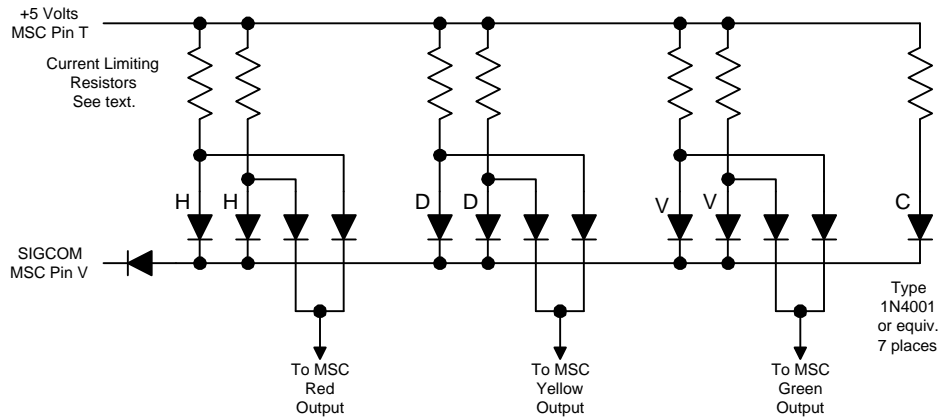
A slightly different circuit is used if you want to have approach lighting. Incidentally, you can use this next circuit with or without approach lighting. It will work either way, but requires the addition of a few diodes. The diodes are not expensive, and type 1N4001 diode is perfectly ok. The resistor used with the center LED may have to be somewhat lower in value because of the additional voltage drop caused by the 1N4001 diodes. This drop will be 0.7 volts added to the forward drop of the center LED itself. If the center LED is obviously dimmer than the others, select a lower value for its resistor. Be careful not to go too low in value and allow too high a current to flow through the LED.



**Figure 5-14 Wiring Position Light LED Signals for Approach Lighting**

For either of the above circuits, set the output type jumpers for the common anode configuration, as shown in Figure 5-8.

While the circuit below can be used with signals wired with common cathodes, the additional complexity is obvious. We recommend that, if possible, you purchase signals wired with common anodes. Also, using these signals with approach lighting is really not at all practical.



**Figure 5-15 Wiring Position Light LED Signals with Common Cathodes**

### 5.4.2.2 Incandescent Bulb Heads

The MSC will handle position light signals equipped with bulbs, as long as they are wired with common anodes. They are wired in the same way as the LED signal shown in Figure 5-14. Simply substitute bulbs for the LED's, and select current limiting resistors as described earlier.

### 5.4.3 Color Position Light Signals

Color position light signals are wired the same as position light signals. The only change is that the center LED or bulb is eliminated. Follow the appropriate wiring diagram shown above, making this one alteration.

### 5.4.4 Searchlight Signals

Searchlight signals are a very interesting and popular signal with many prototype roads. We can build working searchlight signals very simply by using LED's which output two colors: red and green. There are two different types of such LED's, and the MSC will operate both types equally well.

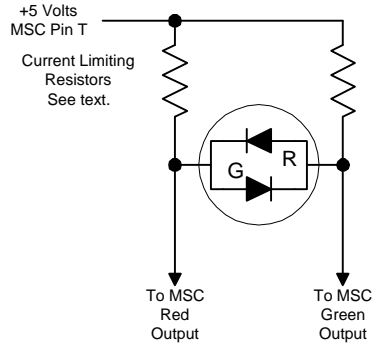
One type is built with red and green LED's wired with opposite polarities to the two external connection pins. For such 2-pin LED's, the polarity of the current will control the color displayed. With one polarity, the LED will shine red; reverse the polarity and the LED will shine green. If you alternate the polarity fast enough, and properly control the percent of the time that the each LED is on, you can get what appears to be a yellow color from the LED.

Another way used to implement two color LED's is to put red and green LED's in the same case, connect their cathodes together, and bring out three pins: the common cathode, and the separate red and green anodes. By grounding the common cathode and causing current to flow through one of the other two leads, you can get either a red or green color emitted. Yellow is also possible with this type of two color LED. The MSC will activate the green side of the LED, and then pulse the red on and off at a high speed, blending the two colors to get yellow.

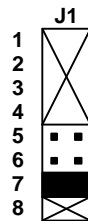
An adjustment is available on the board so you can adjust the yellow tint to get the most acceptable results. This potentiometer is shown as 'R49' in Figure 5-1.

#### 5.4.4.1 Two Pin LED's

The figure below shows how to wire a searchlight signal built with a 2-pin LED. Choose the resistor values as described above. The signal type jumpers for this type of signal head are shown in Figure 5-17.



**Figure 5-16 Searchlight Signal with 2-Pin LED**

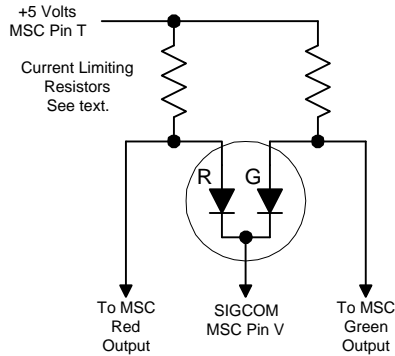


**Figure 5-17 Searchlight Signal with 2-Pin Two Color LED**

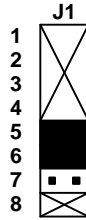
### 5.4.4.2 Three Pin LED's

Searchlight signals are also built with 3-pin LED's. In this case, the two cathodes are common and connected to SIGCOM. To get a yellow aspect, the MSC will turn on the green side and pulse the red side at high speed. You can use R49 to adjust the color blend to get a satisfactory yellow.

Set the signal jumpers as shown in Figure 5-19 to enable use of this type of signal.

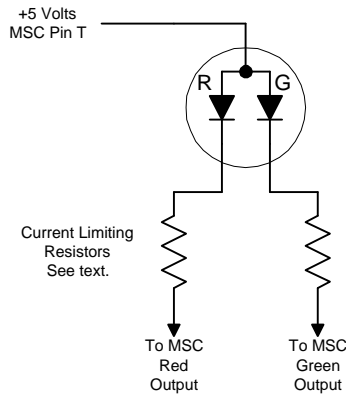


**Figure 5-18 Wiring of a 3-Pin Common Cathode Searchlight Signal**

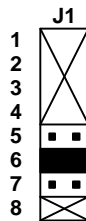


**Figure 5-19 Searchlight Signal with 3-Pin Common Cathode LED**

The MSC will also control searchlight signal heads built with 3-pin LED's having the anodes wired in common. The next two figures show the wiring and output signal type jumper configuration.



**Figure 5-20 Wiring of a 3-Pin Common Anode Searchlight Signal**



**Figure 5-21 Searchlight Signal with 3-Pin Common Anode LED**

### 5.4.5 Semaphore Signals

The MSC will, of course, control semaphore signals. In particular, it works very well with the TOMAR searchlight signals. These signals use a stall motor and three position electrical contact to allow the motor to stall in either the red or green position, or to seek a neutral position between red and green to position the arm in the approach position.

Set the output type jumpers to the common anode color light mode shown in Figure 5-9. Then, simply wire the motor drive as shown in the TOMAR instructions.

The motor drive operates from an external 12-volt DC power supply. Use the same supply with a suitable dropping resistor to light the bulb.

## 5.5 Connecting to a CTC Panel

Several of the MSC modes are CTC modes, and provisions are made to connect the MSC to the direction clearance switch on the dispatcher's panel. The diagram below shows exactly how to do this.

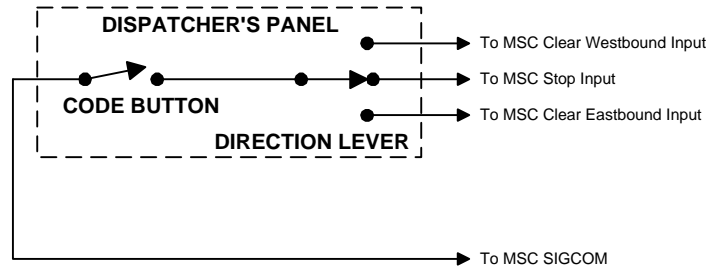


Figure 5-22 Dispatcher's Panel Input Connections

## 6 CUSTOMER SUPPORT

### 6.1 Technical Support

We are available to provide reasonable assistance to help you get the greatest possible benefit from the MSC Master Signal Controller. Feel free to write, email, fax or phone us with any questions or comments you may have. Please enclose a large SASE if you are expecting a reply. We will do our best to clear up any issues you may raise about the use of the MSC.

We welcome any suggestions you may have for improvements to the MSC, or for any related products you would like to see made available. All such recommendations will be considered as we plan our future product offerings.

You can write to us at:

W. S. Ataras Engineering, Inc.  
PO Box 37  
Shelburn, IN 47879  
VOICE: 812-533-1345 (9-4 edt)  
FAX: 708-570-6140

### 6.2 Limited Warranty

Your satisfaction with your new MSC is our primary concern. The MSC Master Signal Controller is warranted free of defects in materials and workmanship for a period of 90 days from date of purchase. This does not cover damage due to misuse-use, improper installation, or connection to excessive voltages or currents. We will, at our option, repair or replace any defective unit.

The MSC Master Signal Controller is further warranted for 30 days to perform in a satisfactory manner when connected as described in this manual. Should you feel that your MSC is not performing as you would expect, simply write to us, describing your difficulty. Tell us what you expect of the MSC, and how it appears to fall short. If we cannot clear up any problems you have, we will refund your full purchase price upon return of your MSC in good working order.

Naturally, we cannot be responsible for units that have been damaged by misuse-use, improper installation or connection.

**OTHER SIGNALING  
AND LAYOUT CONTROL  
PRODUCTS WE SUPPLY**

BD16 Block Occupancy Detector for 16 blocks  
BD8 Block Occupancy Detector for 8 blocks  
TC4 Three Color Signal Controller  
MSC Master Signal Controller  
GCC Grade Crossing Controller  
GCX Grade Crossing Expander  
Detectable Wheel Sets  
Signal Mounting Adapters  
TOMAR Signals, switch stands, crossing gates and flashing cross bucks  
Sunrise signals for N-scale and HO-scale  
Oregon Rail Supply signals and signal kits

And our new CLICS™ System

**COMPLETE LAYOUT INTEGRATED CONTROL SYSTEM**